

# MK2

## WITH CLAMPING HUB

0.5 - 10 Nm



### PROPERTIES

#### FEATURES

- ▶ for highly dynamic applications
- ▶ easy installation
- ▶ light weight and low moment of inertia

#### DESIGN

Two clamping hubs concentrically mounted to flexible bellows.

#### MATERIAL

- ▶ **Bellows:** high grade stainless steel
- ▶ **Hubs:** aluminium

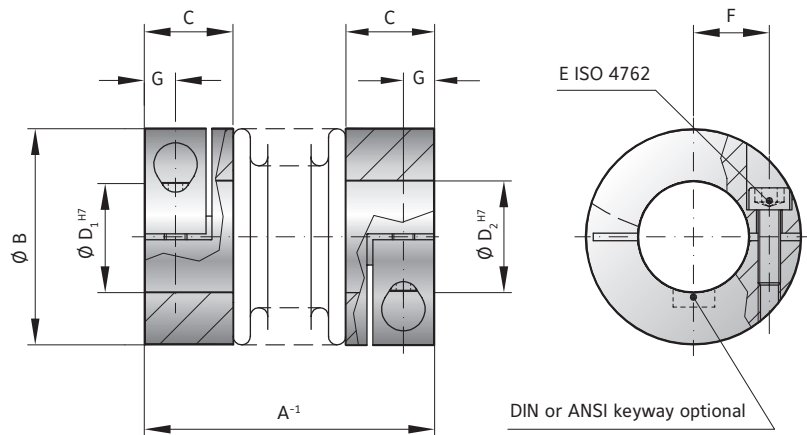

MINIATURE  
COUPLINGS MK

## MODEL MK2

SIZE		5			10			15		20			45		100	
Rated torque (Nm)	T <sub>KN</sub>	0.5			1.0			1.5		2.0			4.5		10	
Overall length (mm)	A <sup>-1</sup>	25	28	31	27	30	33	30	35	35	40	44	46	54	50	60
Outside diameter (mm)	B	15			15			19		25			32		40	
Fit length (mm)	C	9			9			11		13			16		16	
Inside diameter possible from Ø to Ø H7 (mm)	D <sub>1/2</sub>	3-7			3-7			3-8		3-12.7			5-16		5-24	
Fastening screw ISO 4762	E	M2			M2			M2.5		M3			M4		M4	
Tightening torque of the fastening screw (Nm)		0.43			0.43			0.85		2.3			4		4.5	
Distance between centerlines (mm)	F	4.5			4.5			6		8			10		15	
Distance (mm)	G	3			3			3.5		4			5		5	
Moment of inertia (gcm <sup>2</sup> )	J <sub>ges</sub>	2.6	2.8	3	3	3.4	3.6	8.5	9.5	25	27	29	100	108	160	205
Approximate weight (g)		9	9	9	9	10	11	22	24	36	38	40	74	78	120	130
Torsional stiffness (Nm/rad)	C <sub>T</sub>	280	210	170	510	380	320	750	700	1200	1300	1200	7000	5000	9050	8800
Axial (mm)	Max. values	0.4	0.5	0.6	0.4	0.5	0.6	0.5	0.7	0.5	0.6	0.7	0.7	1	1	1.2
Lateral (mm)		0.15	0.2	0.25	0.15	0.2	0.25	0.15	0.2	0.15	0.2	0.25	0.2	0.25	0.2	0.3
Angular (degree)		1	1.5	2	1	1.5	2	1.5	1.5	1.5	1.5	2	1.5	2	1.5	2

ORDERING EXAMPLE	MK2	5	25	4.76	5	XX
Model	●					Special designation only (e.g. special bore tolerance).
Size		●				
Overall length mm			●			
Bore D1 H7				●		
Bore D2 H7					●	

For custom features place an XX at the end of the part number and describe the special requirements (e.g. MK2 / 5 / 25 / 4.76 / 5 / XX; XX=finely balanced for 25,000 rpm)