

THE COUPLING.



PRECISION COUPLINGS

R+W is one thing above all: **THE COUPLING.**

The company Who we are

Day after day, we at R+W make the impossible possible and drive technology for tomorrow. Our couplings are usually only a small component of larger solutions - but they are a decisive factor when it comes to moving components.

Close by worldwide

From our headquarters in Wörth am Main, Germany, we operate as a global industrial enterprise and maintain subsidiaries and sales offices in Italy, France, Slovakia, the USA, China and Singapore.

We attach great importance to close cooperation with our customers and partners. Our goal is to provide our customers with outstanding technical advice and individual development services. That is why we promote our strong and extensive network of more than 80 premium partners and are represented worldwide in over 65 countries close to the market.

Since our founding in 1990, we have developed into the technology leader with in-depth coupling know-how. From batch size 1 we tackle new projects together and implement them consistently.

We produce and deliver more than 1,000,000 couplings annually around the world, from our production facilities in Germany, Slovakia and the USA.



Sustainable Principles

Ecological. Social. Economic. Sustainable development is only possible if we give equal weight to economic growth, social security and ecological compatibility on an equal footing. Our sustainability initiatives take this into account. They span all areas of the company and provide a comprehensive and reliable framework for responsible use of resources.



Natural progress

We are striving to gradually move closer to our goal of zero emissions. To this end, we constantly monitor our consumption levels and rely on technologies and equipment with high resource efficiency. Green energy for our production is provided by a 180-kWp photovoltaic system. The purchased energy comes 100% from hydropower. We reduce process water through targeted fine filtration and cascading.

Social plus

Here, the focus is on those who are the plus at R+W: our employees. We place occupational health and safety at the top of our agenda, and provide continuous investment in this area. A high level of process reliability guarantees the high quality of our couplings and ensures the benefit for our customers.

Long-term value

For success to be sustainable, we must think economically. The prerequisite for this is a modern infrastructure, continuous process improvement in the value chain and cooperation with sustainable suppliers and service providers.



Implementation

How we succeed with Forward thinking



Smart future here today!

With the Intelligent Coupling from R+W Antriebselemente, we are setting a sign for modern developments in the course of digitalization, automation and the Industrial Internet of Things (IIoT).

As a technology leader and specialist, we recognized this early on: The transformation to networked Industry 4.0 cannot be avoided. Data and its efficient use are becoming increasingly valuable. We do not want to simply but to actively help shape it for our customers and turn it into reality.

In drive technology, real-time data acquisition has been a major challenge. The reason: a rotating drive axis cannot be easily connected to a cable – until now! Thanks to the Intelligent Coupling from R+W, this situation has changed fundamentally.

R+W Milestones

New technical standards and superior competitive advantage in elastomer couplings

New standard for TÜV tested safety couplings + development of a special safety coupling for the International Space Station

1993



2001-2004



Development of the first plug-in metal bellows coupling on the market

1999



International openings:
USA (sales office), Slovakia (component production) and China (sales office)

2006

More R+W Couplings

For further information and products please refer to our catalogs of precision and/or industrial couplings.



The new generation of coupling: Intelligent couplings with built-in sensor technology



2008



Additional site opening in Italy

2020

2023



Sales office in Chicago becomes a full production facility

Precision Couplings

0.05 – 25,000 Nm

Model	Features	Page
BK	Torsionally stiff bellows couplings from 2 – 10,000 Nm <ul style="list-style-type: none">• Torsionally stiff• Low moment of inertia• Zero backlash• Highly concentric• Naturally very well balanced• Precise transmission• Infinite life• Wear and maintenance free• Easy to install	18
MK	Torsionally stiff miniature bellows couplings from 0.05 – 10 Nm <ul style="list-style-type: none">• Zero backlash• Torsionally stiff• Precise transmission• Infinite life• Easy to install	38
SCL	Backlash free servo disc pack coupling from 25 – 100 Nm <ul style="list-style-type: none">• High misalignment compensation• Corrosive and/or high temperature environments• Easy installation	52

Model	Features	Page
EK SP	<p>Backlash free Servomax® elastomer couplings from 0.5 – 25,000 Nm</p> <ul style="list-style-type: none"> • Vibration damping • Electrically isolating • Backlash free • Calibrated preloaded insert • Concentrically machined hubs 	60
SK SL ES	<p>Backlash free torque limiters from 0.1 – 2,800 Nm</p> <ul style="list-style-type: none"> • Protects from rotating inertia as well as motor torque • Precise torque overload protection • Patented preload for zero backlash • Compact simple design • Low moment of inertia • Extremely fast disengagement • Low residual friction after disengagement 	78
ZA EZ	<p>Backlash free an smooth running line shafts from 9 – 25,000 Nm</p> <ul style="list-style-type: none"> • Installation and removal without disturbing adjacent equipment • Self-supporting up to 6 meters • No intermediate support bearing required 	102
ATEX	<p>For use in hazardous environments For hazard zones 1/21 and 2/22 these couplings are authorized under directive 94/9/EG.</p> <ul style="list-style-type: none"> • Bellows couplings • Elastomer couplings • Torque limiters • Line shafts • Disc pack couplings 	116

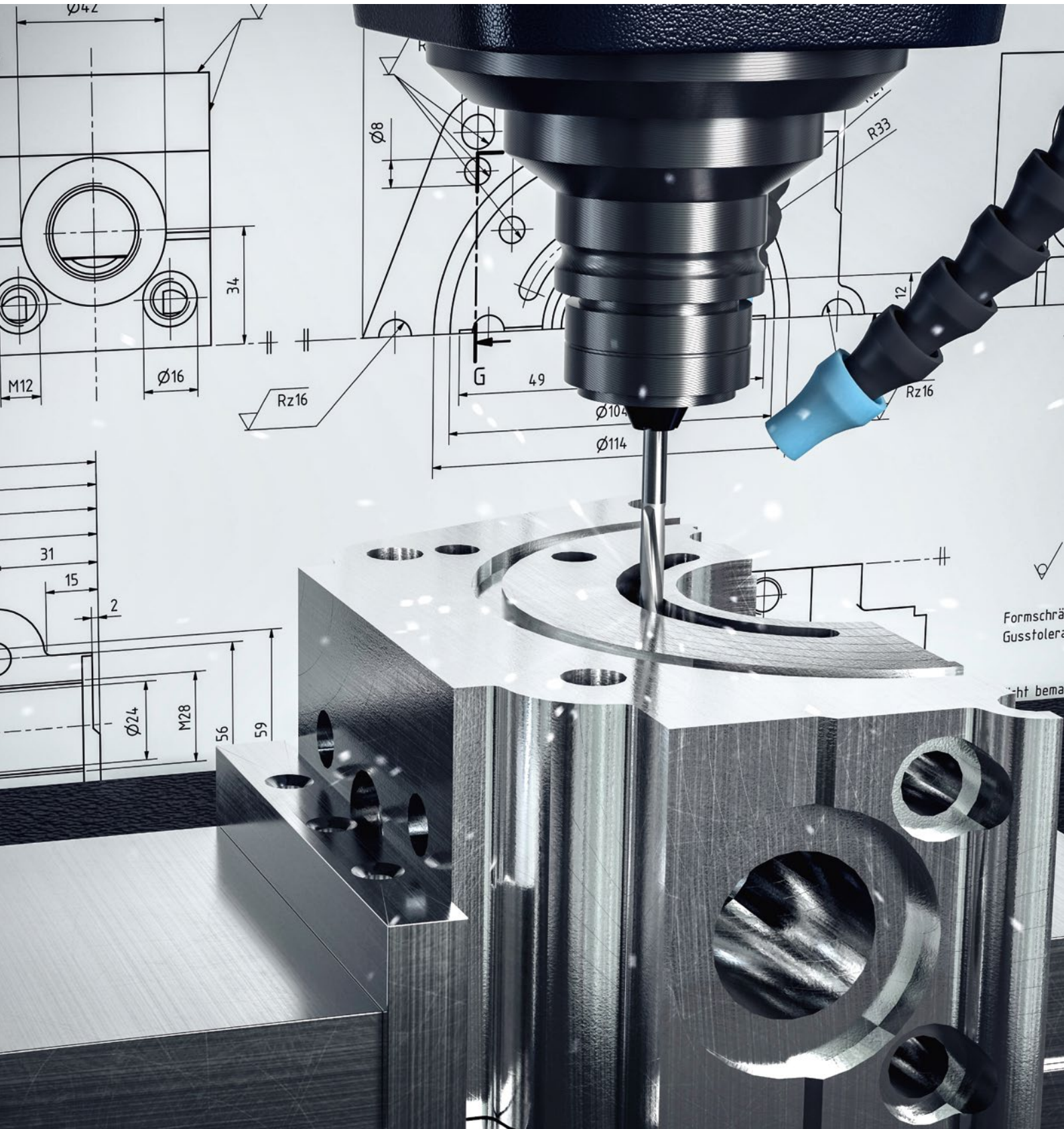

Formschrägung
Gusstoleranz
...ht bema

Sizing and selection



Proper sizing of couplings is crucial to ensuring smooth and efficient power transmission. This involves taking the specific requirements and operating conditions of the application into account. Various factors such as torque, speed, temperature and shock loads must be considered when selecting the correct coupling type and size.

According to DIN 740 part 2

Legend Guide book precision couplings

T_{KN}	=	Rated torque of the coupling (Nm)
T_{KMAX}	=	Maximum torque rating of the coupling (Nm)
T_S	=	Peak torque applied to the coupling (Nm)
T_{AS}	=	Peak torque of the drive system (Nm)
T_{AN}	=	Nominal torque of the drive system (Nm)
T_{LN}	=	Nominal torque of the load (Nm)
P	=	Drive power (kW)
n	=	Drive speed (min. ⁻¹)
s	=	Screw lead (mm)
t	=	Acceleration / deceleration time (s)
ω	=	Angular velocity (1/s)
F_V	=	Feed force (N)
η	=	Spindle efficiency
d_0	=	Pinion dia. (pulley) (mm)
J_1	=	Moment of inertia of driving coupling half (kgm ²)
J_2	=	Moment of inertia of driven coupling half (kgm ²)
J_L	=	Total load inertia (e.g. spindle + slide + workpiece) (kgm ²)
J_A	=	Total driving inertia (motor [including gear ratio]) (kgm ²)
$J_{Masch.}$	=	Total load inertia (e.g. spindle + slide + workpiece + ½ of coupling) (kgm ²)
$J_{Mot.}$	=	Total driving inertia (motor [including gear ratio] + ½ of coupling) (kgm ²)
m	=	Ratio of the moment of inertia of the drive to the load
C_T	=	Torsional stiffness of the coupling (Nm/rad)
f_e	=	Natural frequency of the two mass system (Hz)
f_{er}	=	Excitation frequency of the drive (Hz)
φ	=	Torsional deflection (degree)
α	=	Angular acceleration (1/s ²)
v	=	Temperature at the coupling (observed radiant heat)
S_V	=	Temperature factor
S_A	=	Load factor
S_Z	=	Start factor (factor for the number of starts per hour)
Z_h	=	Number of starts per hour (1/h)

Sizing and selection

Formulas

According to troque

Couplings are normally sized for the highest torque to be regularly transmitted. The peak torque of the application should not exceed the rated torque of the coupling. The following calculation provides an approximation of the minimum required coupling size, and allows for the maximum rated speed and misalignment to exist in the application:

$$T_{KN} \geq 1.5 \cdot T_{AS} \text{ (Nm)}$$

According to accleration torque

A more detailed calculation takes acceleration and the driving and driven moments of inertia into account. A strong inertia ratio diminishes the effect of the load factor in the sizing calculation.

$$T_{KN} \geq T_{AS} \cdot S_A \cdot \frac{J_L}{J_A + J_L} \text{ (Nm)}$$

According to resonant frequency

The torsional natural frequency of the coupling must be significantly higher or lower than that of the equipment. For the mechanical substitution model the two mass system applies.

In practice the following applies: $f_e \geq 2 \cdot f_{er}$

$$f_e = \frac{1}{2 \cdot \pi} \sqrt{C_T \cdot \frac{J_A + J_L}{J_A \cdot J_L}} \text{ (Hz)}$$

Two Mass System

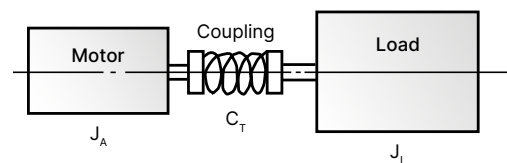

According to torsional defelction

To calculate transmission error as a result of torsional stress:

$$\varphi = \frac{180}{\pi} \cdot \frac{T_{AS}}{C_T} \text{ (degree)}$$

Sizing and selection

Torque limiters

According to load holding function system

Load Holding Version

The SK1, SKP, and SKN models in the load holding version can secure a minimum of 2x their torque setting after disengagement. The SK2, SK3, and SK5 models can secure only up to the torque rating of the flexible bellows after disengagement.

Radial loads



The models shown above have an integral bearing (1) to support the drive attachment (e.g. timing belt or chain sprocket, gear, or hand wheel). The maximum radial load (2) is listed in the table below.

If the center of the overhung load is located within dimension range (S) no additional bearing support is necessary. For offset mounting additional bearings can be used to support the load. This is useful in cases where the attached component is too small to fit over the coupling output flange or has a large width.

Depending on the installation space, ball, roller or needle bearings can all be used.

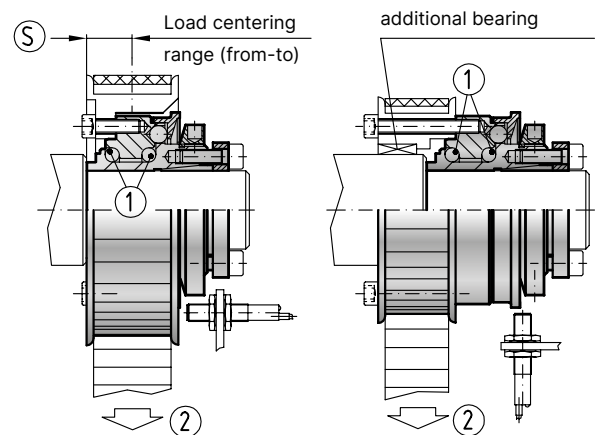

Size SK1/SKN/SKP	1.5	2	4.5	10	15	30	60	150	200	300	500	800	1,500	2,500
Max. radial load (N)	50	100	200	500	1,400	1,800	2,300	3,000	3,500	4,500	5,600	8,000	12,000	20,000
(S) from-to (mm)	3-6	5-8	5-11	6-14	7-17	10-24	10-24	12-24	12-26	12-28	16-38	16-42	20-50	28-60

Size SLN/SLP	30	60	150	300
Max. radial load (N)	800	1,000	1,200	1,600
(S) from-to (mm)	4-14	5-18	6-20	6-23

Sizing and selection

Formulas

According to disengagement torque

Torque limiters are generally selected according to the required disengagement torque, which must be greater than the torque required for regular operation. The disengagement of the torque limiter is most commonly determined in accordance with the drive data. For this purpose, the following calculation applies:

$$T_{KN} \geq 9,550 \cdot \frac{P}{n} \cdot 1.5 \text{ (Nm)}$$

According to acceleration (start-up with no load)

$$T_{KN} \geq \frac{J_L}{J_A + J_L} \cdot T_{AS} \cdot S_A \geq \alpha \cdot J_L \text{ (Nm)}$$

$$\alpha = \frac{\omega}{t} = \frac{\pi \cdot n}{t \cdot 30}$$

According to acceleration with load (start-up under load)

$$T_{KN} \geq \left[\frac{J_L}{J_A + J_L} \cdot (T_{AS} - T_{AN}) + T_{AN} \right] \cdot S_A \geq \alpha \cdot J_L + T_{AN} \text{ (Nm)}$$

According to linear feed force

Spindle Drive (ball screw / lead screw)

$$T_{AN} = \frac{s \cdot F_v}{2,000 \cdot \pi \cdot \eta} \text{ (Nm)}$$

Belt Drive / Chain Drive

$$T_{AN} = \frac{d_0 \cdot F_v}{2,000} \text{ (Nm)}$$

Elastomer couplings

Temperature factor S_u	A	B	C	E
Temperature (u)	Sh 98 A	Sh 64 D	Sh 80 A	Sh 64 D
> -30°C to -10°C	1.5	1.3	1.4	1.2
> -10°C to +30°C	1.0	1.0	1.0	1.0
> +30°C to +40°C	1.2	1.1	1.3	1.0
> +40°C to +60°C	1.4	1.3	1.5	1.2
> +60°C to +80°C	1.7	1.5	1.8	1.3
> +80°C to +100°C	2.0	1.8	2.1	1.6
> +100°C to +120°C	-	2.4	-	2.0
> +120°C to +150°C	-	-	-	2.8

Coupling selection for operation without shock or reversal

The rated torque of coupling (T_{KN}) must be greater than the rated torque of the load (T_{LN}) taking into account the temperature at the coupling (Temperature factor S_u). Should T_{LN} be unknown, T_{AN} can be used as a substitute in the formula.

Calculation

$$T_{KN} > T_{AN} \cdot S_u$$

Supplemental Calculation

$$T_{AN} = \frac{9,550 \cdot P}{n}$$

Coupling selection for operation with shock loads

Same basic conditions as above. In addition, the maximum torque rating of the coupling (T_{Kmax}) is dictated by peak torque (T_s) due to shock loads.

Calculation

$$T_{KN} > T_{AN} \cdot S_u$$

Supplemental Calculation

$$T_{AN} = \frac{9,550 \cdot P}{n}$$

Calculation

$$T_{Kmax} > T_s \cdot S_z \cdot S_u$$

Supplemental Calculation

$$T_s = \frac{T_{AS} \cdot S_A}{m + 1}$$

$$m = \frac{J_A + J_1}{J_L + J_2}$$

Sizing and selection

Line shafts

Symbols

A	=	Total length (mm)
AB	=	Distance between flextures (mm) $AB = (A - 2 \times N)$
Z	=	Tube length (mm) $Z = (A - 2 \times H)$
H	=	Length of coupling ends (mm)
N	=	Length to flexure (mm)
T_{AS}	=	Peak torque of the drive (Nm)
ϕ	=	Torsional deflection (degree)
C_T^B	=	Torsional stiffness of both flexible elements (Nm/rad)
C_T^{ZWR}	=	Torsional stiffness per 1m of tubing (Nm/rad)
C_T^{ZA}	=	Total torsional stiffness (Nm/rad)
n_k	=	Critical speed (1/min.)
C_{Tdyn}^E	=	Dynamic torsional stiffness of both elastomer inserts (Nm/rad)
C_{Tdyn}^{EZ}	=	Total torsional stiffness (Nm/rad)

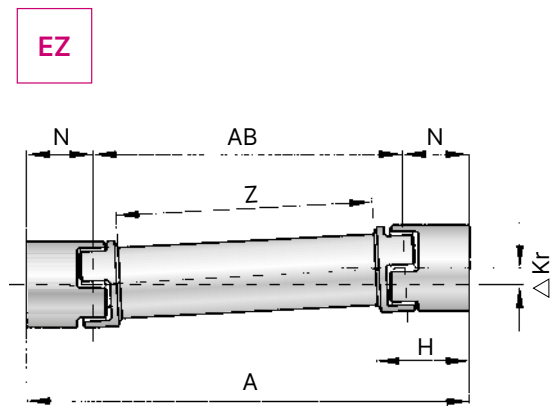
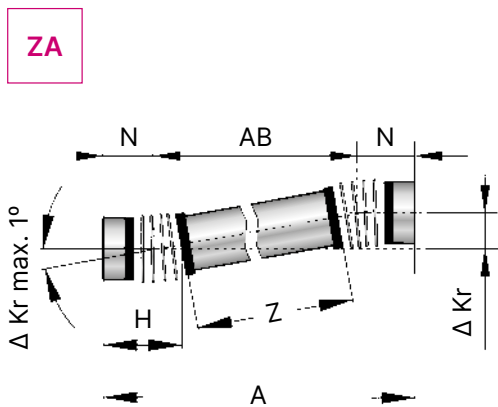

Installation

The overall length A is best determined as the distance between shaft ends P plus 2x dimension O.

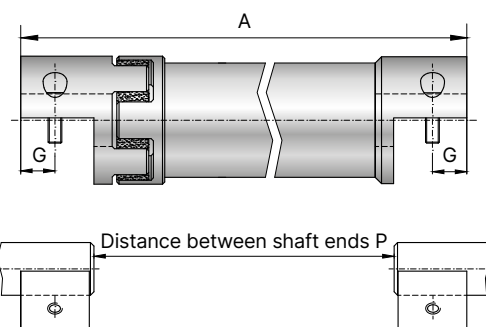

Sizing and selection

Line shafts

Model ZA

Size	Torsional stiffness of both bellows bodies	Torsional stiffness per 1m of standard tubing	Torsional stiffness per 1m of CFK tubing	Length of coupling ends ZA	Length of coupling ends ZAE	Length to flexure	Maximum Axial misalignment
	C_T^B (Nm/rad)	C_T^{ZWR} (Nm/rad)	C_T^{ZWR} (Nm/rad)	H (mm)	H (mm)	N (mm)	ΔKa (mm)
10	4,525	1,770	2,892	44.5	39.5	25	2
30	19,500	6,440	8,931	57.5	52	34	2
60	38,000	11,500	17,120	71	64	41	3
150	87,500	24,000	46,679	78	72	47	4
200	95,500	73,000	-	86	-	52	4
300	250,500	220,000	87,438	94	83	56	4
500	255,000	297,000	149,111	110	96	66	5
800	475,000	389,000	230,467	101	89	64	6
1,500	1,400,000	775,000	-	92	-	56	4
4,000	4,850,000	1,160,000	-	102	-	61	4

Table 1

Model EZ

Size	Torsional stiffness of both flexible elements		Torsional stiffness per 1m of tubing	Working length EZ	Length to flexure	Max. axial misalignment
	Elastomer insert A CTB (Nm/rad)	Elastomer insert B CTB (Nm/rad)	C_T^{ZWR} (Nm/rad)	H (mm)	N (mm)	ΔKa (mm)
5	150	350	503	25	18	2
10	270	825	727	34	26	2
20	1,270	2,220	1,770	46	33	3
60	3,970	5,950	6,440	63	49	3
150	6,700	14,650	11,500	73	57	3.6
300	11,850	20,200	24,000	86	67	4
450	27,700	40,600	73,000	99	78	4
800	41,300	90,000	389,000	125	94	4
2,500	87,500	108,000	950,000	142	108	6
4,500	168,500	371,500	2,200,000	181	137	6
9,500	590,000	670,000	5,500,000	229	171	8

Table 2

Sizing and selection

Line shafts

According to torsional stiffness

Condition: Line shaft ZA, size 150 $T_{AS} = 150$ Nm
 Wanted: Total torsional stiffness C_T^{ZA}

$$(C_T^{ZA}) = \frac{87,500 \text{ Nm/rad} \times (24,000 \text{ Nm/rad} / 1.344 \text{ m})}{87,500 \text{ Nm/rad} + (24,000 \text{ Nm/rad} / 1.344 \text{ m})} = 14,830 \text{ [Nm/rad]}$$

$$(C_T^{ZA}) = \frac{C_T^B \cdot (C_T^{ZWR}/Z)}{C_T^B + (C_T^{ZWR}/Z)} \text{ (Nm/rad)}$$

According to torsional deflection

Condition: Line shaft ZA, size 150 $T_{AS} = 150$ Nm
 Wanted: Torsional deflection at maximum acceleration torque T_{AS}

$$\varphi = \frac{180 \cdot T_{AS}}{\pi \cdot C_T^{ZA}} \text{ (degree)}$$

Measurement (A) of line shaft = 1,5 m
 Length (Z) of Tubing = $A - (2 \times H) = 1,344$ m

$$\varphi = \frac{180 \times 150 \text{ Nm}}{\pi \times 14,830 \text{ Nm/rad}} = 0.579^\circ$$

With a maximum torque of 150 Nm the torsional deflection is 0.579°

According to maximum misalignment

	Lateral misalignment ΔKr	Angular misalignment ΔKw	Axial misalignment ΔKa
ZA			
EZ			
	$\Delta Kr_{\max} = \tan \Delta \frac{Kw}{2} \cdot AB$ $AB = A - 2 \times N$	$\Delta Kw_{\max} = 2^\circ$	see table 1/2 (page 16)



BK

Backlash free, torsionally stiff metal bellows couplings

2 – 10,000 Nm

Areas of application

for highly dynamic motion in:

- + Machine tools
- + Packaging machinery
- + Printing machinery
- + Paper converting machinery
- + Labeling machinery
- + Automation equipment

Service life

R+W bellows couplings are fatigue resistant and wear free for an infinite service life, as long as the technical limits are not exceeded.

Temperature range

-30°C to 100°C

Fit clearance

Overall shaft / hub clearance of 0.01 - 0.05 mm

Special solutions

Various materials, tolerances, dimensions and performance ratings available for custom applications on request.

Rotational speed

Standard up to 10,000 rpm.

Over 10,000 rpm in finely balanced version; up to grade ISO G=2.5 is available.

ATEX (Optional)





Available on request





Ordering Example	BK2	30	69	14	16	XX
Model	•					Special designation only (e.g. anodized hubs).
Size		•				
Overall length mm			•			
Bore Ø D1 H7				•		
Bore Ø D2 H7					•	

For custom features place an XX at the end of the part number and describe the special requirements (e.g. BK2 / 30 / 69 / 14 / 16 / XX=finely balanced for 25,000 rpm)

Torsionally stiff bellows couplings

2 – 10,000 Nm



Model		Features	Page
BK1		<p>With simple flange mounting 15 – 10,000 Nm</p> <ul style="list-style-type: none"> • For adapting the metal bellows to custom drive components • Custom flange patterns available 	23
BK2		<p>With clamping hub 15 – 10,000 Nm</p> <ul style="list-style-type: none"> • Easy to mount • Available in multiple lengths • Low moment of inertia 	24-25
BKH		<p>With split clamping hub 15 – 4,000 Nm</p> <ul style="list-style-type: none"> • Radial mounting possible • Easy to install onto pre-aligned shafts • Low moment of inertia 	26
BKL		<p>Economy class with clamping hub 2 – 500 Nm</p> <ul style="list-style-type: none"> • Easy to mount • Optional self-opening clamp system • Low moment of inertia 	27
BKC		<p>Compact version with clamping hub 15 – 500 Nm</p> <ul style="list-style-type: none"> • Low moment of inertia • Compact design • Optional self-opening clamp system 	28

Model	Features	Page
 <p>BKM</p>	<p>Torsional stiff with clamping hub 20 – 1,000 Nm</p> <ul style="list-style-type: none"> • High torque density • Ultra compact • Lowest moment of inertia of all clamping hub designs 	29
 <p>BKS</p>	<p>Welded with clamping hub 15 – 500 Nm</p> <ul style="list-style-type: none"> • All stainless steel construction • Temperatures up to 300°C • Easy to mount 	30
 <p>BK3</p>	<p>With conical clamping hub 15 – 10,000 Nm</p> <ul style="list-style-type: none"> • High clamping pressure • Modern design for removal system • Highly reliable 	31
 <p>SP3</p>	<p>With external clamping ring 60 – 10,000 Nm</p> <ul style="list-style-type: none"> • Highly concentric symmetrical design • Very true running to the shaft axis • For high speed applications 	32
 <p>BK5</p>	<p>With clamping hub and blind mate connection 15 – 1,500 Nm</p> <ul style="list-style-type: none"> • Backlash free with two piece design • Easy installation and removal • Available as separate components 	33

BK

Torsionally stiff bellows couplings

2 – 10,000 Nm

Model		Features	Page
BK6		With conical clamping ring and blind mate connection 15 – 1,500 Nm <ul style="list-style-type: none">• Eliminates need for screw access holes• Self centering hubs for highly concentric mounting• Easy installation and removal	34
BK7		With expanding shaft 15 – 300 Nm <ul style="list-style-type: none">• For hollow shaft mounting• Save space and cost• Solution for mismatched shaft/bore diameters	35
BK8		With ISO flange mounting 50 – 2,600 Nm <ul style="list-style-type: none">• For flange output gearboxes• allows for continuous hollow through axis with some right angle gearbox designs• compact layout	36

BK1

With flange mounting

15 – 10,000 Nm

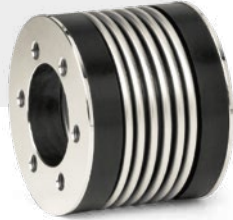

Features

- For simple flange mounting to special drive components
- Custom flange patterns available

Material

- **Bellows:** high grade stainless steel
- **Hubs:** steel

Design

Two mounting flanges concentrically assembled to the flexible bellows. Brief overloads of up to 1.5x the rated torque are acceptable.

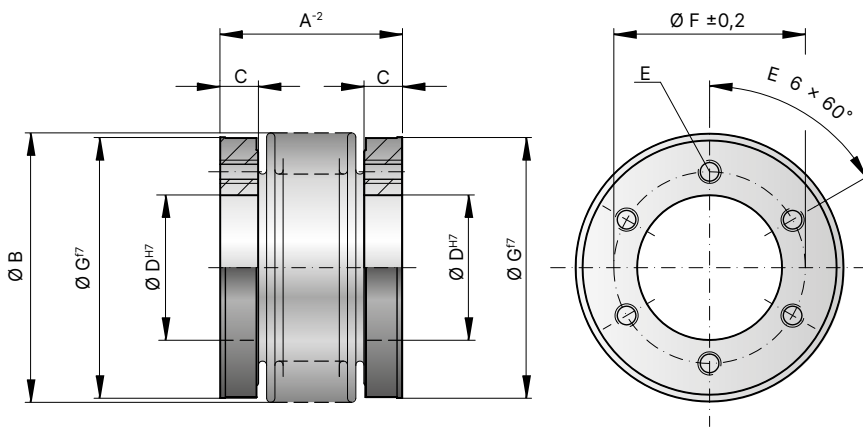

Model BK1

Size		15	30	60	150	200	300	500	800	1,500	4,000	6,000	10,000
Rated torque (Nm)	T_{KN}	15	30	60	150	200	300	500	800	1,500	4,000	6,000	10,000
Overall length (mm)	A^2	30 37	36 44	43 53	50 62	53 65	56 70	64 77	81	100	145	138	150
Outside Ø of bellows (mm)	B	49	55	66	81	90	110	124	133	157	200	253	303
Fit length/thread depth (mm)	C	7,5	10	11	13	14,5	15	16	18	22	30	30	36
Inside diameter H7 (mm)	D	25	28	38	50	58	65	70	75	85	100	145	190
Fastening threads	E	6 x M5	6 x M5	6 x M6	6 x M6	6 x M6	6 x M8	6 x M8	6 x M10	6 x M16	6 x M20	8 x M20	8 x M24
Bolt circle diameter ± 0.2 (mm)	F	35	37	46	62	70	80	94	90	110	140	190	234
Outside diameter f7 (mm)	G	49	55	66	81	90	110	122	116	140	182	235	295
Moment of inertia (10 ⁻³ kgm ²)	J_{ges}	0.07 0.08	0.14 0.15	0.30 0.32	0.90 0.95	1.30 1.40	1.95 2.10	3.0 3.4	4.3	10.6	46	132	350
Approximate weight (kg)		0.15	0.2	0.3	0.6	0.8	1.35	1.8	1.9	3.3	8.9	13.9	23.7
Torsional stiffness (10 ³ Nm/rad)	C_T	20 15	39 28	76 55	175 110	191 140	450 350	510 500	780	1,304	3,400	5,700	10,950
Axial ± (mm)		1 2	1 2	1.5 2	2 3	2 3	2.5 3.5	2.5 3.5	3.5	3.5	3.5	3	3
Lateral ± (mm)	$Max. values$	0.15 0.2	0.2 0.25	0.2 0.25	0.2 0.25	0.25 0.3	0.25 0.3	0.3 0.35	0.35	0.35	0.4	0.4	0.4
Angular ± (degree)		1 1.5	1 1.5	1 1.5	1 1.5	1 1.5	1 1.5	1 1.5	1.5	1.5	1.5	1.5	1.5
Axial spring stiffness (N/mm)	C_a	25 15	50 30	72 48	82 52	90 60	105 71	70 48	100	320	565	1,030	985
Lateral spring stiffness (N/mm)	C_r	475 137	900 270	1,200 420	1,550 435	2,040 610	3,750 1,050	2,500 840	2,000	3,600	6,070	19,200	21,800

BK2

With clamping hub

15 – 200 Nm



Features

- Easy to mount
- Light weight and low moment of inertia

Material

- **Bellows:** high grade stainless steel
- **Hubs:** see table

Design

Two clamping hubs concentrically mounted to flexible bellows. Brief overloads of up to 1.5x the rated torque are acceptable.

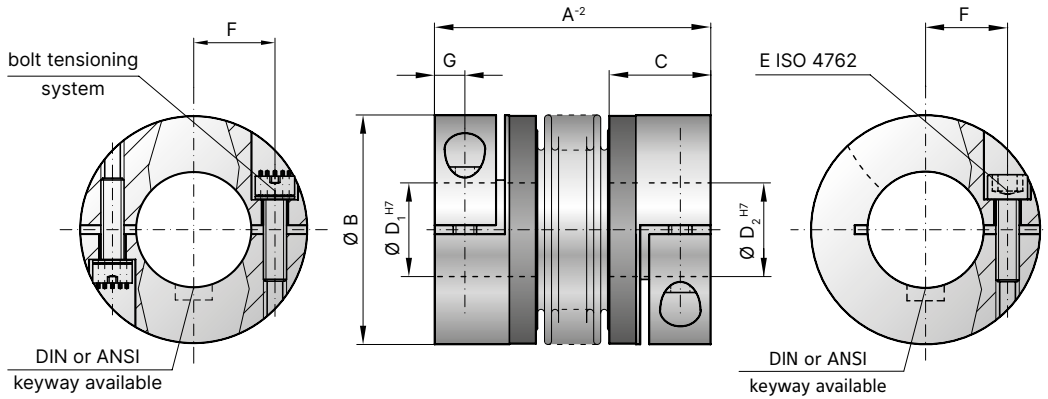

Advantage: reduce screw tightening torques by up to 90% by using multiple smaller screws to create the same tension.

Optionally also available in other materials.

Model BK2

Size			15			30			60			80			150			200		
Rated torque (Nm)	T_{KN}		15			30			60			80			150			200		
Overall length (mm)	A^{-2}		59	66	99	69	77	113	83	93	130	94	106	143	95	107	144	105	117	163
Outside diameter (mm)	B		49			55			66			81			81			90		
Fit length (mm)	C		22			27			31			36			36			41		
Inside diameter possible from \varnothing to \varnothing H7 (mm)	D_1/D_2		8-28			10-30			12-35			14-42			19-42			22-45		
Fastening screw ISO 4762			M5			M6			M8			M10			M10			M12		
Tightening torque of the fastening screw (Nm)	E		8			15			40			50			70			120		
Distance between centerlines (mm)	F		17			19			23			27			27			31		
Distance (mm)	G		6.5			7.5			9.5			11			11			12.5		
Moment of inertia (10^{-3} kgm ²)	J_{ges}		0.06	0.07	0.08	0.12	0.13	0.14	0.32	0.35	0.4	0.8	0.85	0.9	1.9	2	2.1	3.2	3.4	3.6
Hub material			AL optional steel			AL optional steel			AL optional steel			AL optional steel			steel optional AL			steel optional AL		
Approximate weight (kg)			0.16			0.26			0.48			0.8			1.85			2.65		
Torsional stiffness (10^3 Nm/rad)	C_T		20	15	14	39	28	27	76	55	54	129	85	84	175	110	97	191	140	135
Axial \pm (mm)			1	2	3	1	2	3	1.5	2	3	2	3	4	2	3	4	2	3	4
Lateral \pm (mm)		Max. values	0.15	0.2	1	0.2	0.25	1	0.2	0.25	1	0.2	0.25	1	0.2	0.25	1	0.25	0.3	1
Angular \pm (degree)			1	1.5	2	1	1.5	2	1	1.5	2	1	1.5	2	1	1.5	2	1	1.5	2
Axial spring stiffness (N/mm)	C_a		25	15	84	50	30	118	72	48	165	48	32	144	82	52	130	90	60	280
Lateral spring stiffness (N/mm)	C_r		475	137	140	900	270	224	1,200	420	337	920	290	401	1,550	435	500	2,040	610	750

* 180° opposed in each clamping hub.

BK2

With clamping hub

300 – 10,000 Nm



Features

- Easy to mount
- Light weight and low moment of inertia
- Optional: bolt tensioning system in size 800 and up

Material

- **Bellows:** high grade stainless steel
- **Hubs:** see table

Design

Two clamping hubs concentrically mounted to flexible bellows. Brief overloads of up to 1.5x the rated torque are acceptable.

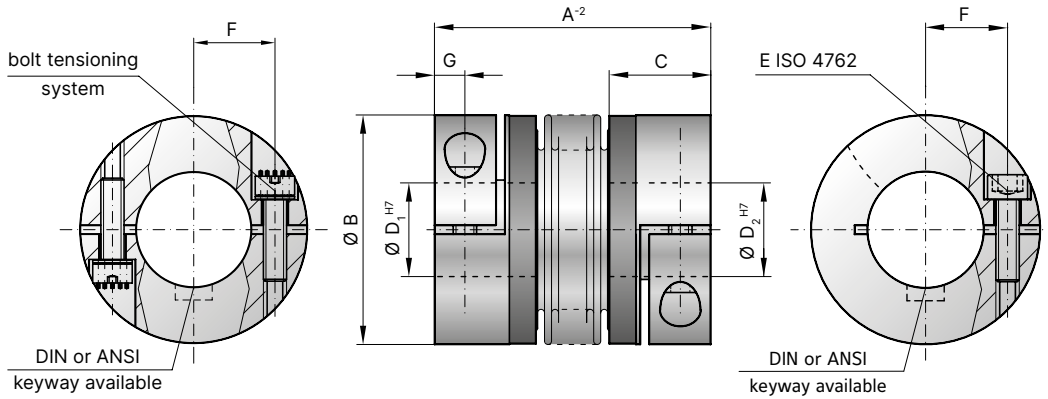

Advantage: reduce screw tightening torques by up to 90% by using multiple smaller screws to create the same tension.

Optionally also available in other materials.

Model BK2

Size			300			500			800		1,500		4,000		6,000		10,000	
Rated torque (Nm)	T_{KN}		300			500			800		1,500		4,000		6,000		10,000	
Overall length (mm)	A^{-2}		111	125	200	133	146	169	140	179	166	230	225	252	288			
Outside diameter (mm)	B		110			124			134		157		200		253		303	
Fit length (mm)	C		43			51			45		55		85		107		129	
Inside diameter possible from \varnothing to \varnothing H7 (mm)	D_1/D_2		24-60			35-60			40-75		50-80		50-90		60-140		70-180	
Fastening screw ISO 4762			M12			M16			2x M16*		2x M20*		2x M24*		2x M24*		2x M30*	
Tightening torque of the fastening screw (Nm)	E		130			200			250		470		1,200		1,200		2,400	
Distance between centerlines (mm)	F		39			41			2x48		2x55		2x65		2x90		2x117	
Distance (mm)	G		13			16.5			18		22.5		28		35		42	
Moment of inertia (10^{-3} kgm ²)	J_{ges}		7.6	7.9	8.3	14.3	14.6	14.8	16.2	17	43	45	165	495	1,214			
Hub material			steel optional AL			steel optional AL			steel		steel		steel		steel		steel	
Approximate weight (kg)			4			6.3			5.7		11.5		28.8		49.4		80.9	
Torsional stiffness (10^3 Nm/rad)	C_T		450	350	340	510	500	400	780	711	1,304	1,180	3,400	5,700	10,950			
Axial \pm (mm)	C_{max}		2.5	3.5	4.5	2.5	3.5	4.5	3.5	4.5	3.5	4.5	3.5	3	3			
Lateral \pm (mm)			0.25	0.3	1	0.3	0.35	1	0.35	1	0.35	1	0.4	0.4	0.4			
Angular \pm (degree)			1	1.5	2	1	1.5	2	1.5	2	1.5	2	1.5	1.5	1.5			
Axial spring stiffness (N/mm)	C_a		105	71	605	70	48	85	100	285	320	440	565	1,030	985			
Lateral spring stiffness (N/mm)	C_r		3,750	1,050	1,200	2,500	840	614	2,000	1,490	3,600	1,700	6,070	19,200	21,800			

* 180° opposed in each clamping hub.

BKH

With split clamping hub

15 – 4,000 Nm



Features

- Radial mounting possible
- Easy installation onto pre-aligned shafts
- Low moment of inertia

Material

- **Bellows:** high grade stainless steel
- **Hubs:** see table

Design

Two split clamping hubs with two screws in each.
Brief overloads of up to 1.5x the rated torque are acceptable.

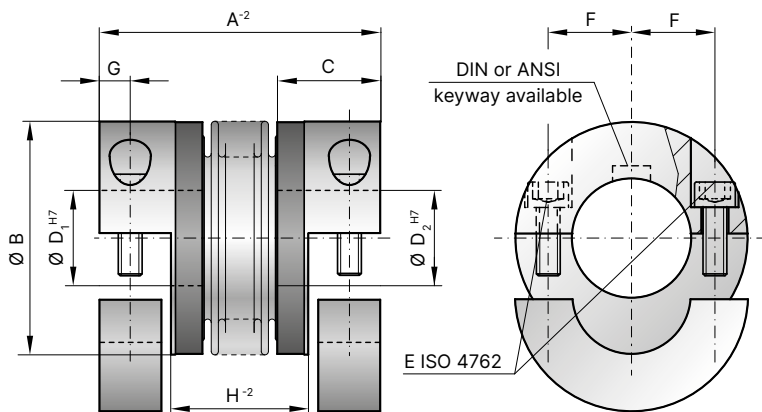

Model BKH

Size			15	30	60	80	150	200	300	500	800	1,500	4,000
Rated torque (Nm)	T_{KN}		15	30	60	80	150	200	300	500	800	1,500	4,000
Overall length (mm)	A^{-2}		59 66	69 77	83 93	94 106	95 107	105 117	111 125	133 146	140 166	166 225	
Outside diameter (mm)	B		49	55	66	81	81	90	110	124	134	157	200
Fit length (mm)	C		22	27	31	36	36	41	43	51	45	55	85
Inside diameter possible from Ø to Ø H7 (mm)	D_1/D_2		8-28	10-30	12-35	14-42	19-42	22-45	24-60	35-60	40-75	50-80	50-90
Fastening screw ISO 4762			M5	M6	M8	M10	M10	M12	M12	M16	M16	M20	M24
Tightening torque of the fastening screw (Nm)	E		8	15	40	50	70	120	130	200	250	470	1,200
Distance between centerlines (mm)	F		17.5	19	23	27	27	31	39	41	48	55	65
Distance (mm)	G		7	7.5	9.5	12	12	12.5	14	16.5	18	22.5	28
Length of center section (mm)	H^{-2}		29 36	35 43	41 51	47 59	48 60	50 62	55 69	61 75	65.5 71	71 109	
Moment of inertia (10^{-3} kgm^2)	J_{ges}		0.07 0.08	0.14 0.15	0.23 0.26	0.65 0.67	2.5 3.2	4.5 5.4	8.5 10.5	17.3 19.6	24.3 24.3	49.2 49.2	165
Approximate weight (kg)			0.15	0.3	0.4	0.8	1.7	2.5	4	7.5	7	12	28
Torsional stiffness (10^3 Nm/rad)	C_T		20 15	39 28	76 55	129 85	175 110	191 140	450 350	510 500	780 780	1,304 1,304	3,400
Axial ± (mm)			1 2	1 2	1.5 2	2 3	2 3	2 3	2.5 3.5	2.5 3.5	3.5 3.5	3.5 3.5	3.5
Lateral ± (mm)		Max. values	0.15 0.2	0.2 0.25	0.2 0.25	0.2 0.25	0.2 0.25	0.25 0.3	0.25 0.3	0.3 0.35	0.35 0.35	0.35 0.35	0.4
Angular ± (degree)			1 1.5	1 1.5	1 1.5	1 1.5	1 1.5	1 1.5	1 1.5	1 1.5	1 1.5	1.5 1.5	1.5
Axial spring stiffness (N/mm)	C_a		25 15	50 30	72 48	48 32	82 52	90 60	105 71	70 48	100 100	320 320	565
Lateral spring stiffness (N/mm)	C_r		475 137	900 270	1,200 420	920 290	1,550 435	2,040 610	3,750 1,050	2,500 840	2,000 2,000	3,600 3,600	6,070

BKL

With clamping hub

2 – 500 Nm**Features**

- Easy to mount
- Light weight and low moment of inertia

Material

- **Bellows:** high grade stainless steel
- **Hubs:** see table

Design

Two clamping hubs concentrically mounted to flexible bellows. Brief overloads of up to 1.5x the rated torque are acceptable.

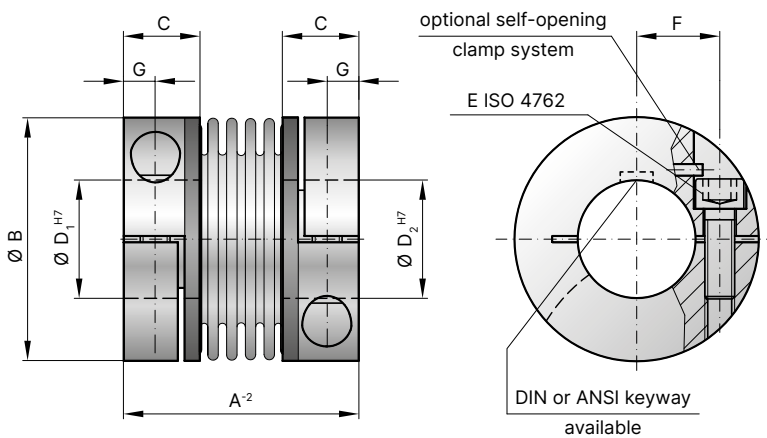

Optional: self-opening clamp system to open the bore during installation and removal by backing out the clamping screw.

Model BKL

Size			2	3	4.5	10	15	30	60	80	150	300	500			
Rated torque (Nm)	T_{KN}		2	3	4.5	10	15	30	60	80	150	300	500			
Overall length (mm)	A^{-2}		30	32	40	44	58	68	79	92	92	109	114			
Outside diameter (mm)	B		25	25	32	40	49	56	66	82	82	110	123			
Fit length (mm)	C		10	10	13	13	21.5	26	28	32.5	32.5	41	42.5			
Inside diameter possible from \varnothing to \varnothing H7 (mm)	$D_{1/2}$		4-12.7	3-12.7	6-16	6-24	8-28	10-32	14-35	16-42	19-42	24-60	35-62			
Fastening screw ISO 4762			M3	M3	M4	M4	M5	M6	M8	M10	M10	M12	M16			
Tightening torque of the fastening screw (Nm)	E		2.3	2.3	4	4.5	8	15	40	70	85	120	200			
Distance between centerlines (mm)	F		8	8	11	14	17	20	23	27	27	39	41			
Distance (mm)	G		4	3.8	5	5	6.5	7.5	9.5	11	11	13	17			
Moment of inertia (10^{-3} kgm ²)	J_{ges}		0.002	20	0.007	0.016	0.065	0.12	0.3	0.75	1.8	0.8	7.5	3.1	11.7	4.9
Approximate weight (kg)			0.02	0.023	0.05	0.06	0.16	0.25	0.4	0.7	1.7	0.75	3.8	1.6	4.9	2.1
Torsional stiffness (10^3 Nm/rad)	C_T		1.5	0.994	7	9	23	31	72	80	141	157	290			
Axial \pm (mm)			0.5	1	1	1	1	1	1.5	2	2	2	2.5			
Lateral \pm (mm)		Max. values	0.2	0.2	0.2	0.2	0.2	0.2	0.2	0.2	0.2	0.2	0.2			
Angular \pm (degree)			1	2	1	1	1	1	1	1	1	1	1			
Axial spring stiffness (N/mm)	C_a		8		35	30	30	50	67	44	77	112	72			
Lateral spring stiffness (N/mm)	C_r		50		350	320	315	366	679	590	960	2,940	1,450			

BKC

Compact design with clamping hub

15 – 500 Nm**Features**

- For space restricted installations
- Light weight and low moment of inertia
- Easy to mount

Material

- **Bellows:** high grade stainless steel
- **Hubs:** see table

Design

Two clamping hubs concentrically mounted to flexible bellows. Brief overloads of up to 1.5x the rated torque are acceptable.

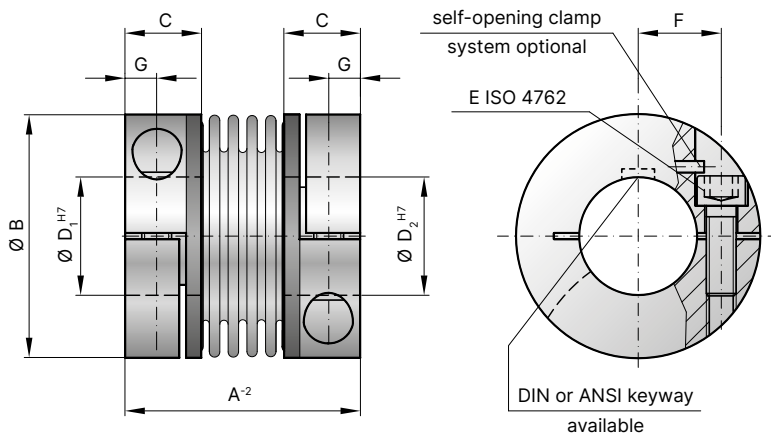

Optional: self-opening clamp system to open the bore during installation and removal by backing out the clamping screw.

Model BKC

Size			15	30	60	150	300	500
Rated torque	(Nm)	T_{KN}	15	30	60	150	300	500
Overall length	(mm)	A^{-2}	48	58	67	78	94	100
Outside diameter	(mm)	B	49	56	66	82	110	123
Fit length	(mm)	C	16.5	21	23	27.5	34	34
Inside diameter possible from \emptyset to \emptyset H7	(mm)	D_1/D_2	8-28	12-32	14-35	19-42	24-60	32-75
Fastening screw ISO 4762			M5	M6	M8	M10	M12	M12
Tightening torque of the fastening screw	(Nm)	E	8	15	40	75	120	125
Distance between centerlines	(mm)	F	17.5	20	23	27	39	45
Distance	(mm)	G	6.5	7.5	9.5	11	13	13
Moment of inertia	(10^{-3} kgm^2)	$J_{ges.}$	0.05	0.1	0.26	0.65	6.3	9
Hub material			AL	AL	AL	AL	steel	steel
Approximate weight	(kg)		0.13	0.21	0.37	0.72	3.26	3.52
Torsional stiffness	(10^3 Nm/rad)	C_T	23	31	72	141	157	290
Axial	\pm (mm)	Max. values	1	1	1.5	2	2	2.5
Lateral	\pm (mm)		0.2	0.2	0.2	0.2	0.2	0.2
Angular	\pm (degree)		1	1	1	1	1	1
Axial spring stiffness	(N/mm)	C_a	30	50	67	77	112	72
Lateral spring stiffness	(N/mm)	C_l	315	366	679	960	2,940	2,200
Speed max. with balancing	(min^{-1})		80,000	70,000	60,000	50,000	40,000	30,000

BKM

Torsional stiff with clamping hub

20 – 1,000 Nm**Features**

- Extremely compact
- High torque density
- High torsional stiffness

Material

- **Bellows:** high grade stainless steel
- **Hubs:** see table

Design

Two clamping hubs concentrically mounted to flexible bellows. Brief overloads of up to 1.5x the rated torque are acceptable.

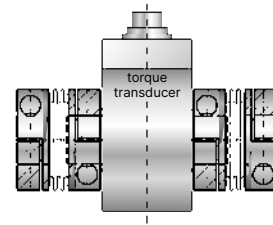
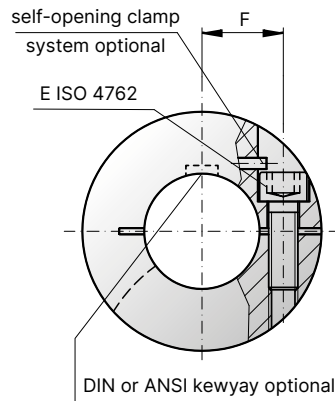
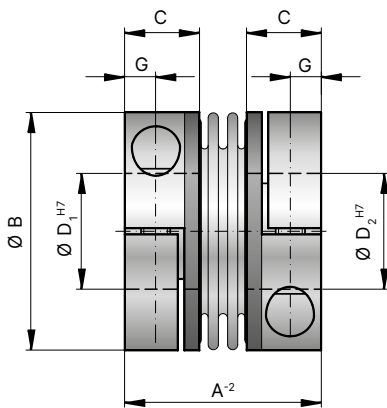

Key application:
For mounting on a torque transducer.

Model BKM

Size			20	200	400	1,000
Rated torque	(Nm)	T_{KN}	20	200	400	1,000
Overall length	(mm)	A^{-2}	40	59	75	89
Outside diameter	(mm)	B	49	66	82	110
Fit length	(mm)	C	16.5	23	27.5	34
Inside diameter possible from \varnothing to \varnothing H7	(mm)	$D_{1/2}$	15-28	24-35	32-42	40-60
Fastening screw ISO 4762			M5	M8	M10	M12
Tightening torque of the fastening screw	(Nm)	E	8	40	60	130
Distance between centerlines	(mm)	F	17	23	27	39
Distance	(mm)	G	6	9.5	11	13
Moment of inertia	(10^{-3} kgm ²)	$J_{ges.}$	0.05	0.18	0.62	7.2
Hub material			AL	AL	AL	steel
Approximate weight	(kg)		0.13	0.4	0.7	3.5
Torsional stiffness	(10^3 Nm/rad)	C_T	41.9	138	170	570
Axial	\pm (mm)	Max. values	1	1.5	1	2
Lateral	\pm (mm)		0.06	0.08	0.1	0.1
Angular	\pm (degree)		0.5	0.5	0.5	0.5
Axial spring stiffness	(N/mm)	C_a	55.8	153	114	148
Lateral spring stiffness	(N/mm)	C_r	3,710	11,000	6,058	9,010
Speed max. with balancing	(min ⁻¹)		80,000	60,000	50,000	40,000

BKS

Welded with clamping hub

15 – 500 Nm



Features

- For high temperatures and aggressive media
- Compact design
- Welded version

Material

- **Bellows:** high grade stainless steel
- **Hubs:** high grade stainless steel
- **Screws:** Grade 12.9 Geomet coated (alternate materials on request)

Design

Two clamping hubs concentrically mounted to flexible bellows. Brief overloads of up to 1.5x the rated torque are acceptable. From -40°C to +300°C operating temperature.

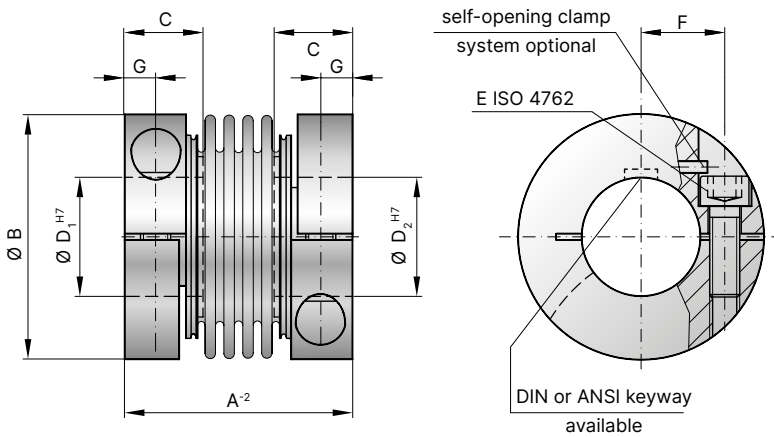

Optional: self-opening clamp system to open the bore during installation and removal by backing out the clamping screw.

Model BKS

Size			15	30	60	150	300	500
Rated torque	(Nm)	T_{KN}	15	30	60	150	300	500
Overall length	(mm)	A^{-2}	45	52	66	76	89	95
Outside diameter	(mm)	B	49	56	66	82	110	123
Fit length	(mm)	C	17	20	24	30	34	35
Inside diameter* possible from \varnothing to \varnothing H7	(mm)	D_1/D_2	12-28	14-32	14-35	19-42	24-60	32-75
Fastening screw ISO 4762			M5	M6	M8	M10	M12	M12
Tightening torque of the fastening screw	(Nm)	E	8	15	40	75	120	125
Distance between centerlines	(mm)	F	17.5	20	23	27	39	45
Distance	(mm)	G	6	7.5	9.5	11	13	13
Moment of inertia (10^{-3} kgm ²)		$J_{ges.}$	0.1	0.2	0.53	1.5	5.5	8.1
Approximate weight	(kg)		0.27	0.42	0.78	1.5	2.9	3.5
Torsional stiffness (10^3 Nm/rad)		C_T	23	31	72	141	157	290
Axial	\pm (mm)	Max. values	1	1	1.5	2	2	2.5
Lateral	\pm (mm)		0.2	0.2	0.2	0.2	0.2	0.2
Angular	\pm (degree)		1	1	1	1	1	1
Axial spring stiffness	(N/mm)	C_a	30	50	67	77	112	72
Lateral spring stiffness	(N/mm)	C_r	315	366	679	960	2,940	2,200
Speed max. with balancing	(min ⁻¹)		60,000	50,500	50,000	40,500	40,000	30,000

* Smaller bore diameter available at reduced torque capacity

BK3

With conical clamping system

15 – 10,000 Nm



Features

- High clamping pressure
- High torque version
- Compact design
- Suitable for space restricted installation spaces, with easy removal due to jack screws

Material

- **Bellows:** high grade stainless steel
- **Hubs:** steel

Design

Two conical clamping hubs concentrically mounted to flexible bellows. Brief overloads of up to 1.5x the rated torque are acceptable.

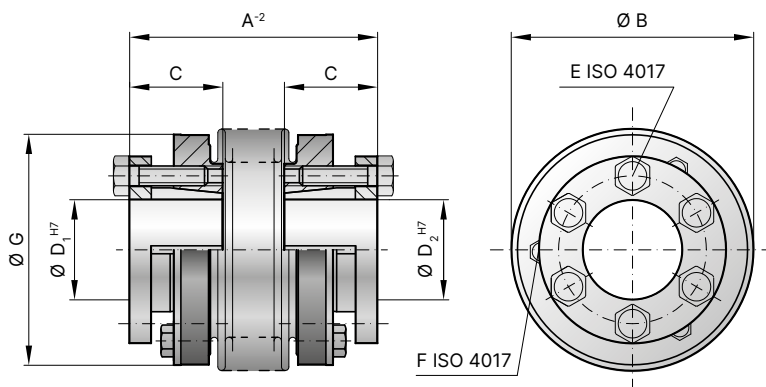

Model BK3

Size		15	30	60	150	200	300	500	800	1,500	4,000	6,000	10,000
Rated torque (Nm)	T_{KN}	15	30	60	150	200	300	500	800	1,500	4,000	6,000	10,000
Overall length without screw head (mm)	A^{-2}	48 55	57 65	66 76	75 87	78 90	89 103	97 110	114	141	195	210	217
Outside diameter (mm)	B	49	55	66	81	90	110	124	133	157	200	253	303
Fit length (mm)	C	19	22	27	32	32	41	41	50	61	80	85	92
Inside diameter possible from Ø to Ø H7 (mm)	$D_{1/2}$	10-22	12-23	12-30	15-37	15-44	24-60	24-60	30-60	35-70	50-100	60-140	70-180
Fastening screw ISO 4017		6 × M4	6 × MS	6 × MS	6 × M6	6 × M6	6 × M8	6 × M8	6 × M10	6 × M12	6 × M16	6 × M16	8 × M16
Tightening torque of the fastening screw (Nm)	E	4	6	8	12	14	18	25	40	70	120	150	160
Jack screw ISO 4017	F	3 × M4	3 × M4	3 × M5	3 × M5	3 × M6	3 × M6	3 × M6	3 × M8	6 × M8	6 × M10	6 × M10	4 × M10
Outside diameter of hub (mm)	G	49	55	66	81	90	110	122	116	135	180	246	295
Moment of inertia (10^{-3} kgm ²)	J_{ges}	0.07 0.08	0.15 0.16	0.39 0.41	1.2 1.6	1.7 2.5	5.1 5.9	9.1 9.9	13.2	34.9	85.5	254	629
Approximate weight (kg)		0.25	0.4	0.8	1.2	1.8	3	4.2	5.6	8.2	23	32.6	45.5
Torsional stiffness (10^3 Nm/rad)	C_T	20 15	39 28	76 55	175 110	191 140	450 350	510 500	780	1,304	3,400	5,700	10,950
Axial ± (mm)		1 2	1 2	1.5 2	2 3	2 3	2.5 3.5	2.5 3.5	3.5	3.5	3.5	3	3
Lateral ± (mm)	$C_{a, values}$	0.15 0.2	0.2 0.25	0.2 0.25	0.2 0.25	0.25 0.3	0.25 0.3	0.3 0.35	0.35	0.35	0.4	0.4	0.4
Angular ± (degree)		1 1.5	1 1.5	1 1.5	1 1.5	1 1.5	1 1.5	1 1.5	1.5	1.5	1.5	1.5	1.5
Axial spring stiffness (N/mm)	C_a	25 15	50 30	72 48	82 52	90 60	105 71	70 48	100	320	565	1,030	985
Lateral spring stiffness (N/mm)	C_r	475 137	900 270	1,200 420	1,500 435	2,040 610	3,750 1,050	2,500 840	2,000	3,600	6,070	19,200	21,800

SP3

With external clamping ring

60 – 10,000 Nm
High speed



Features

- Very high balancing quality due to symmetrical design
- High operating speeds
- Extremely smooth running

Material

- **Bellows:** high grade stainless steel
- **Hubs and clamping ring:** steel

Design

Two precision machined clamping ring hubs mounted concentrically to a flexible bellows. Brief overloads of up to 1.5x the rated torque are acceptable.

Fit clearance

Overall shaft / hub tolerance 0.01 - 0.025 mm

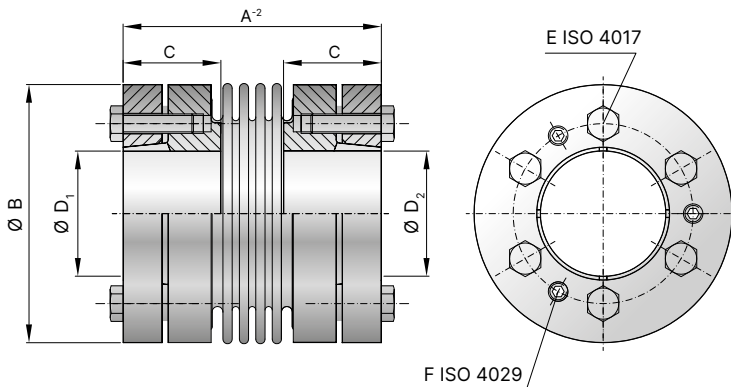

Model SP3

Size		60	150	200	300	500	800	1,500	4,000	6,000	10,000
Rated torque (Nm)	T_{KN}	60	150	200	300	500	800	1,500	4,000	6,000	10,000
Overall length without screw head (mm)	A^{-2}	66 76	75 87	76 88	89 103	97 111	117	133	195	250	300
Outside diameter (mm)	B	66	81	90	110	124	133	157	200	253	300
Fit length (mm)	C	25	30	32	36	40	40	53	65	86	95
Inside diameter possible from \emptyset to \emptyset H7 (mm)	D_1/D_2	14-32	18-35	20-42	22-55	25-60	32-60	42-75	50-100	60-140	70-180
Fastening screw ISO 4017		6 x M5	6 x M6	6 x M6	6 x M8	6 x M8	6 x M10	6 x M10	6 x M12	6 x M16	8 x M16
Tightening torque of the fastening screw (Nm)	E	8.5	14	14	30	35	50	60	120	260	295
Jack screw ISO 4017	F	3 x M5	3 x M6	3 x M6	3 x M8	3 x M8	3 x M10	3 x M10	3 x M12	3 x M16	4 x M16
Moment of inertia (10^{-3} kgm ²)	J_{ges}	0.58 0.60	1.6 1.62	2.42 2.52	6.38 6.56	10.35 10.67	10.9	24.3	107.9	466.2	1,187.4
Approximate weight (kg)		0.9 0.92	1.7 1.8	2.1 2.2	3.52 3.6	4.73 4.83	4.9	7.9	19.0	45.0	80.5
Torsional stiffness (10^{-3} Nm/rad)	C_T	76 55	175 110	191 140	450 350	510 500	780	1,304	3,400	5,700	10,950
Axial \pm (mm)		1.5 2	2 3	2 3	2.5 3.5	2.5 3.5	3.5	3.5	3.5	3.0	3.0
Lateral \pm (mm)	$\begin{matrix} \text{Max.} \\ \text{values} \end{matrix}$	0.2 0.25	0.2 0.25	0.25 0.3	0.25 0.3	0.3 0.35	0.35	0.35	0.4	0.4	0.4
Angular \pm (degree)		1 1.5	1 1.5	1 1.5	1 1.5	1 1.5	1.5	1.5	1.5	1.5	1.5
Axial spring stiffness (N/mm)	C_a	72 48	82 52	90 60	105 71	70 48	100	320	565	1,030	985
Lateral spring stiffness (N/mm)	C_l	1,200 420	1,500 435	2,040 610	3,750 1,050	2,500 840	2,000	3,600	6,070	19,200	21,800
Speed standard (min ⁻¹)	n	22,500	16,500	16,500	13,500	12,500	10,000	8,000	6,000	5,000	3,000

* Recommended fit pairing H7 / k6; H6 / j5 (short spindle); starting at \emptyset 55 G7 / m6

BK5

Blind mate with clamping hub

15 – 1,500 Nm



Features

- Easy installation and removal due to blind mate
- Electrically and thermally isolating
- Absolutely backlash free assembly

Material

- **Bellows:** high grade stainless steel
- **Hubs:** Up through size 80 Aluminum, size 150 and up steel
- **Tapered male segment:** High strength plastic

Design

Two clamping hubs, one of which has a tapered male projection for blind mate connection. Brief overloads of up to 1.5x the rated torque are acceptable.

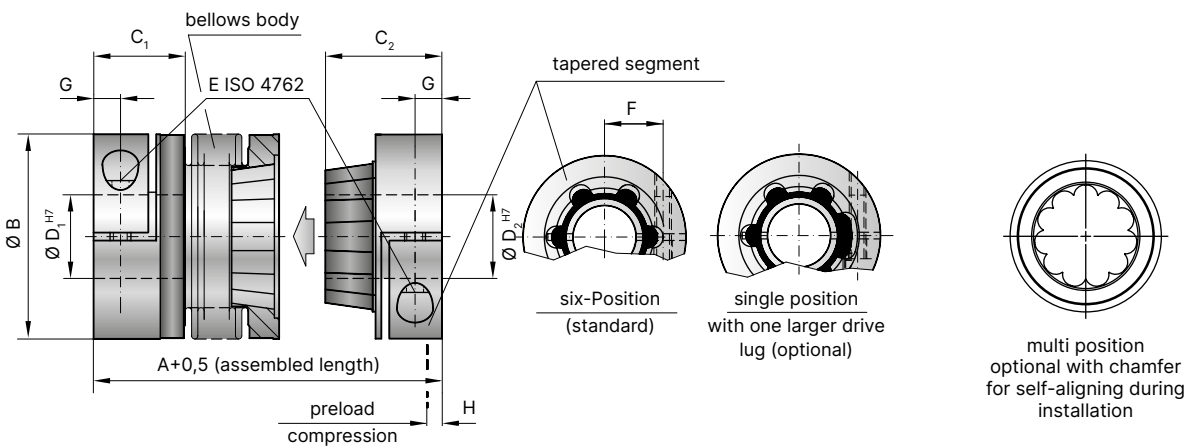

Model BK5

Size		15	30	60	80	150	300	500	800	1,500
Rated torque (Nm)	T_{KN}	15	30	60	80	150	300	500	800	1,500
Overall length (inserted) (mm)	$A^{+0.5}$	60 67	71 79	85 95	94 106	95 107	114 128	136 149	150 176	
Outside diameter (mm)	B	49	55	66	81	81	110	124	133	157
Fit length (mm)	C_1	22	27	31	36	36	43	51	45	55
Fit length (mm)	C_2	28	33	39	43	43	52	61	74	94
Inside diameter possible from \emptyset to $\emptyset H7$ (mm)	D_1	8-28	10-30	12-35	14-42	14-42	24-60	35-60	40-75	50-80
Inside diameter possible from \emptyset to $\emptyset H7$ (mm)	D_2	8-22	10-25	12-32	14-38	14-38	24-58	35-60	40-62	50-75
Fastening screw ISO 4762		M5	M6	M8	M10	M10	M12	M16	2 x M16**	2 x M20**
Tightening torque of the fastening screw (Nm)	E	8	15	40	50	70	130	200	250	470
Distance between centerlines (mm)	F	17	19	23	27	27	39	41	2 x 48**	2 x 55**
Distance (mm)	G	6.5	7.5	9.5	11	11	13	16.5	18	22.5
Preload compression (mm)		0.2 - 1.0	0.5 - 1.0	0.5 - 1.5	0.5 - 1.5	0.5 - 1.5	0.5 - 1.5	1.0 - 2.0	1.0 - 2.5	0.5 - 1.5
Axial recovery force at maximum pretensioning (N)	H	20 12	50 30	70 45	48 32	82 52	157 106	140 96	200	650
Moment of inertia (10^{-3} kgm^2)	J_{ges}	0.07 0.08	0.14 0.15	0.23 0.26	0.65 0.67	2.2 2.4	7.4 7.9	13.7 14.4	21.5	51.4
Approximate weight (kg)		0.1 0.1	0.3 0.3	0.4 0.4	0.9 0.9	1.8 1.8	4 4	6.5 6.7	9	15.3
Torsional stiffness (10^3 Nm/rad)	C_T	10 8	20 14	38 28	65 43	88 55	225 175	255 245	400	650
Axial* \pm (mm)		0.5 1	0.5 1	0.5 1	1 2	1 2	1.5 2	2.5 3.5	3	2
Lateral \pm (mm)	Max. values	0.15 0.2	0.2 0.25	0.2 0.25	0.2 0.25	0.2 0.25	0.25 0.3	0.3 0.35	0.35	0.35
Angular \pm (degree)		1 1.5	1 1.5	1 1.5	1 1.5	1 1.5	1 1.5	1 1.5	1.5	1.5
Lateral spring stiffness (N/mm)	C_r	475 137	900 270	1,200 420	920 290	1,550 435	3,750 1,050	2,500 840	2,000	3,600

*in addition to maximum allowable pretension **180° opposed in each clamping hub.

BK6

Blind mate with conical clamping ring

15 – 1,500 Nm



Features

- Axial mounting possible
- Easy installation and removal due to blind mate
- Naturally very well balanced due to self centering clamping ring system
- Absolutely backlash free assembly

Material

- **Bellows:** high grade stainless steel
- **Hubs:** steel
- **Tapered male segment:** high strength plastic

Design

Two conical clamping ring hubs, one of which has a tapered male projection for blind mate connection.

Brief overloads of up to 1.5x the rated torque are acceptable.

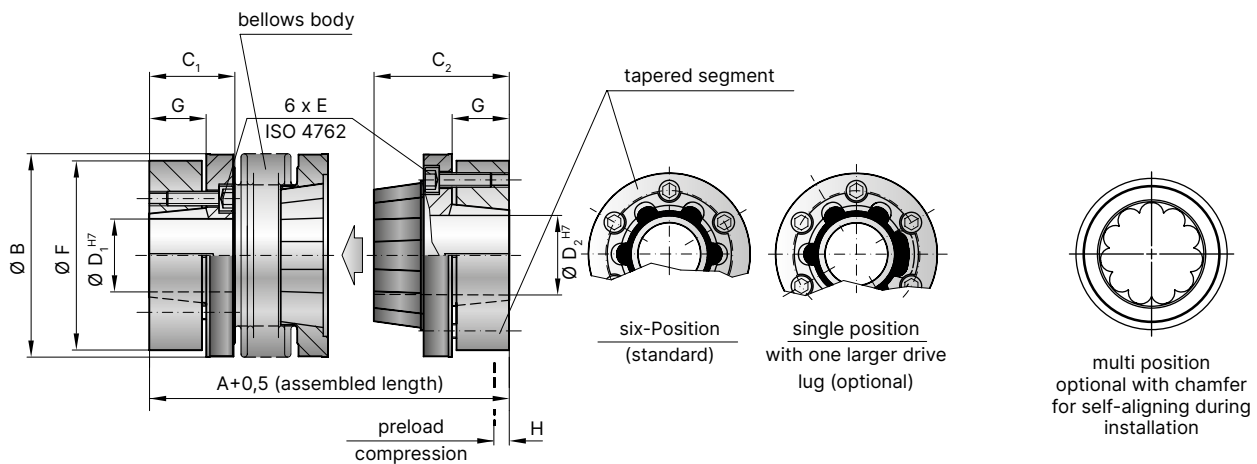

Model BK6

Size		15	30	60	150	300	500	800	1,500
Rated torque (Nm)	T_{KN}	15	30	60	150	300	500	800	1,500
Overall length (inserted) (mm)	$A^{+0,5}$	58 65	68 76	79 89	97 109	113 127	132 145	140 158	158
Outside diameter (mm)	B	49	55	66	81	110	124	133	157
Fit length (mm)	C_1	13.3	21.5	17.5	30	37	32	42.5	53
Fit length (mm)	C_2	29	34	39	49.5	59	68	74	90.5
Inside diameter possible from Ø to Ø H7 (mm)	$D_{1/2}$	10-22	12-24	12-32	15-40	24-56	30-60	40-62	50-75
Fastening screw ISO 4762		M4	M5	M5	M6	M8	M8	M10	M12
Tightening torque of the fastening screw (Nm)	E	3.5	6.5	8	12	30	32	55	110
Diameter of clamping ring (mm)	F	46.5	51	60	74	102	114	126	146
Clamping ring length (mm)	G	9.5	10.5	11.5	17.5	20	23	27	32
Preload compression (mm)		0.2 - 1.0	0.5 - 1.0	0.5 - 1.5	0.5 - 1.5	0.5 - 1.5	1.0 - 2.0	1.0 - 2.0	0.5 - 1.5
Axial recovery force at maximum pretensioning (N)	H	20 12	50 30	70 45	82 52	157 106	140 96	400	650
Moment of inertia (10^{-3} kgm ²)	J_{ges}	0.1 0.12	0.2 0.25	0.4 0.45	2.0 2.5	5.4 6.1	8.4 9.1	17.5	44
Approximate weight (kg)		0.3 0.32	0.5 0.52	0.82 0.84	1.6 1.7	4.1 4.2	6.0 6.3	8.1	16.2
Torsional stiffness (10^3 Nm/rad)	C_T	10 8	20 14	38 28	88 55	225 175	255 245	400	660
axial* ± (mm)		0.5 1	0.5 1	0.5 1	1 2	1.5 2	2.5 3.5	3	2
lateral ± (mm)	Max. values	0.15 0.2	0.2 0.25	0.2 0.25	0.2 0.25	0.25 0.3	0.3 0.35	0.35	0.35
angular ± (degree)		1 1.5	1 1.5	1 1.5	1 1.5	1 1.5	1 1.5	1.5	1.5
Lateral spring stiffness (N/mm)	C_f	475 137	900 270	1,200 420	1,550 435	3,750 1,050	2,500 840	2,000	3,600

* in addition to maximum allowable pretension. Higher torques upon request.

BK7

With expanding shaft

15 – 300 Nm



Features

- For hollow shaft mounting
- Short design saves installation space
- Solution for mismatched shaft / bore

Material

- **Bellows:** high grade stainless steel
- **Hubs:** see table
- **Expanding mandrel system:** steel

Design

One clamping hub on one end with an expanding shaft on the other end. Brief overloads of up to 1.5x the rated torque are acceptable.

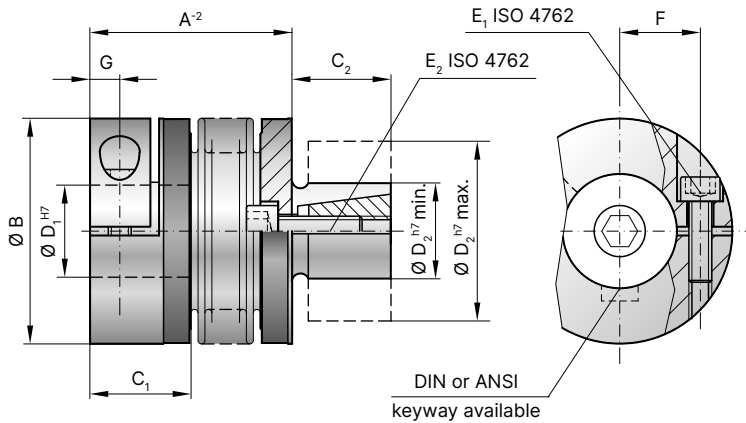

Model BK7

Size			15	30	60	150	300					
Rated torque (Nm)	T_{KN}		15	30	60	150	300					
Overall length (mm)	A^2		45	52	53	61	62	72	71	83	84	98
Outside diameter (mm)	B		49	55	66	81	110					
Fit length (mm)	C_1		22	27	31	36	43					
Shaft length (mm)	C_2		20	25	27	32	45					
Inside diameter possible from \emptyset to $\emptyset H7$ (mm)	D_1		8-28	10-30	12-35	19-42	30-60					
Shaft diameter from \emptyset to $\emptyset h7$ (mm)	D_2		13-25	14-30	23-38	26-45	38-60					
Fastening screw ISO 4762	$E_{1/2}$		M5	M6	M8	M10	M12					
Tightening torque of the fastening screw (Nm)	$E_{1/2}$		8	14	38	65	120					
Distance between centerlines (mm)	F		17	19	23	27	39					
Distance (mm)	G		6.5	7.5	9.5	11	13					
Moment of inertia (10^{-3} kgm^2)	J_{ges}		0.07	0.08	0.14	0.15	0.23	0.26	2.2	2.4	6.5	8.9
Hub material			AL	AL	AL	steel	steel					
Approximate weight (kg)			0.15	0.3	0.4	1.7	4					
Torsional stiffness (10^3 Nm/rad)	C_T		20	15	39	28	76	55	175	110	450	350
axial \pm (mm)			1	2	1	2	1.5	2	2	3	2.5	3.5
lateral \pm (mm)		Max. values	0.15	0.2	0.2	0.25	0.2	0.25	0.2	0.25	0.25	0.3
angular \pm (degree)			1	1.5	1	1.5	1	1.5	1	1.5	1	1.5
Axial spring stiffness (N/mm)	C_a		20	12	50	30	72	48	82	52	105	71
Lateral spring stiffness (N/mm)	C_r		315	108	730	230	1,200	380	1,550	435	3,750	1,050

BK8

With iso flange connection

50 – 2,600 Nm**Features**

- for ISO flange output gearboxes
- allows for continuous hollow through axis with some right angle gearbox designs
- compact design

Material

- **Bellows:** high grade stainless steel
- **Hubs:** up through size 300 aluminum, size 1500 and up steel
- **Adapter flange:** steel

Design

One clamping hub on one end with an integral flange and adapter flange on the other end. Maximum transmittable torque depends on the bore diameter.

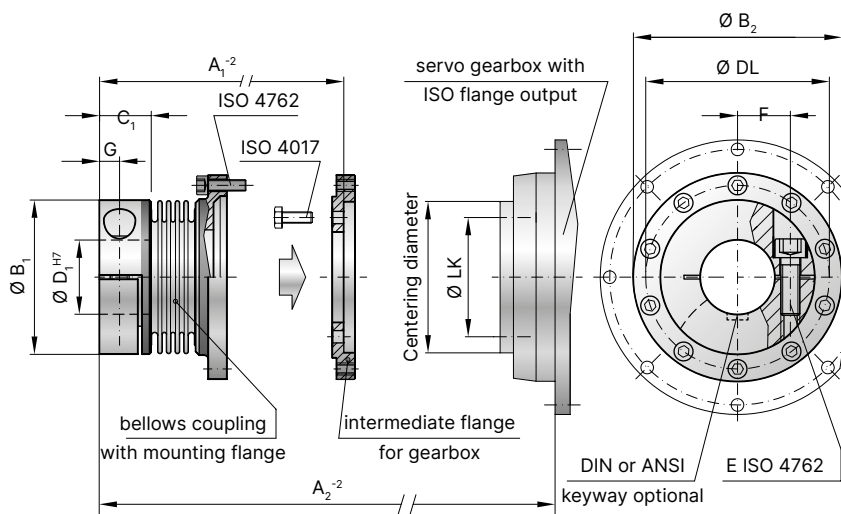

Model BK8

Size			15	60	150	300	1,500
Flange centering diameter	(mm)		40 h7	63 h7	80 h7	100 h7	160 h7
Flange bolt circle / thread Ø	(mm)		31.5 / 8 x M5	50 / 8 x M6	63 / 12 x M6	80 / 12 x M8	125 / 12 x M10
Maximum torque*	(Nm)		50	210	380	750	2,600
Length -2	(mm)	A ₁ ⁻²	48.5	67	72	90	140
Length -2	(mm)	A ₂ ⁻²	68	97	101	128	190
Outside diameter of hub	(mm)	B ₁	49	66	82	110	157
Flange diameter	(mm)	B ₂	63.5	86	108	132	188
Fit length	(mm)	C ₁	16.5	23	27.5	34	55
Inside diameter possible from Ø to Ø H7	(mm)	D ₁	12-28	14-35	19-42	24-60	50-80
Hub bolt circle	(mm)	DL	56.5	76	97	120	170
Fastening threads	(mm)		10 x M4	10 x M5	10 x M6	12 x M6	16 x M8
Fastening screws ISO 4762		E ₁	1 x M5	1 x M8	1 x M10	1 x M12	2 x M20
Tightening torque of the fastening screw	(Nm)		8	45	80	120	470
Distance between centerlines	(mm)	F	1 x 17.5	1 x 23	1 x 27	1 x 39	2 x 55
Distance	(mm)	G	6.5	9.5	11	13	22.5
Approximate weight	(kg)		0.3	0.7	1	2.8	10
Moment of inertia	(10 ⁻³ kgm ²)	J _{ges}	0.15	0.65	1.3	5.5	45
Lateral	± (mm)		0.25	0.25	0.25	0.25	0.25
Angular	± (degree)	Max. values	1	1	1	1	1
Axial	± (mm)		1	1.5	2	2.5	3



MK

Backlash free, torsionally stiff miniature bellows couplings

0.05 – 10 Nm



Areas of application

for precise transmission of angular motion and torque in:

- + Linear actuators
- + Semiconductor machinery
- + Medical devices
- + Lab automation systems
- + Micro pumps
- + Test and measurement systems

Service life

R+W bellows couplings are fatigue resistant and wear free for an infinite service life, as long as the technical limits are not exceeded.

Temperature range

-30°C to +100°C

Fit clearance

Overall shaft / hub clearance of 0.01 - 0.05 mm

Special solutions

Various materials, tolerances, dimensions and performance ratings available for custom applications on request.

Rotational speed

Standard up to 10,000 rpm.

Over 10,000 rpm in finely balanced version; up to grade ISO G=2.5 is available.





ATEX (Optional)





Available on request.

Ordering Example	MK2	10	30	4	6	XX
Model	•					Special designation only (e.g. special bore tolerance).
Size		•				
Overall length mm			•			
Bore Ø D1 H7				•		
Bore Ø D2 H7					•	

For custom features place an XX at the end of the part number and describe the special requirements (e.g. MK2 / 10 / 30 / 4 / 6 / XX=finely balanced for 25,000 rpm)

Backlash free, torsionally stiff miniature bellows couplings 0.05 – 10 Nm

Model		Features	Page
MK1		<p>With radial set screws 0.05 - 10 Nm</p> <ul style="list-style-type: none"> • Large bores available in small size • Integral dismounting groove eliminates the need for flats on shafts • Economy design 	42
MK2		<p>With clamping hub 0.5 - 10 Nm</p> <ul style="list-style-type: none"> • Easy mounting • For highly dynamic applications • Finely balanced versions up to 90,000 rpm 	43
MKH		<p>With split clamping hub 0.5 - 10 Nm</p> <ul style="list-style-type: none"> • Lateral mounting possible • Easy installation and removal • Allows for pre-alignment of shafts 	44
MK3		<p>With expanding shaft 0.5 - 10 Nm</p> <ul style="list-style-type: none"> • Easy installation • Solution for mismatched shaft / bore diameters • Saves space and cost 	45
MK4		<p>With radial set screw and blind mate connection 0.5 - 10 Nm</p> <ul style="list-style-type: none"> • Axial installation possible • Electrically and thermally isolating • Includes integral dismounting groove 	46

Model		Features	Page
MK5		With clamping hub and blind mate connection 0.5 - 10 Nm <ul style="list-style-type: none">• Axial installation possible• Electrically and thermally isolating• Easy mounting and dismounting	47
MK6		With expanding shaft and blind mate connection 0.5 - 10 Nm <ul style="list-style-type: none">• Full axial installation possible• Well suited to restricted installation space• Solution to mismatched bore / shaft diameters	48
MKS		With conical clamping ring 4.5 - 10 Nm <ul style="list-style-type: none">• Speeds up to 120,000 rpm• Naturally very well balanced due in part to self centering clamping system• For high speed high precision applications	49
FK1		With radial set screw up to 1 Ncm <ul style="list-style-type: none">• Well balanced• Sterilizable	50

MK1

With radial set screws

0.05 – 10 Nm



Features

- Integral dismounting groove eliminates the need for flats on shafts
- Economical design
- Larger bore diameters in a small size possible

Material

- **Bellows:** size 0.5 tombac; sizes 1 and up high grade stainless steel
- **Hubs:** aluminium

Design

Two hubs with radial set screws concentrically mounted to flexible bellows. Speeds up to 20,000 rpm; over 20,000 with finely balanced version.

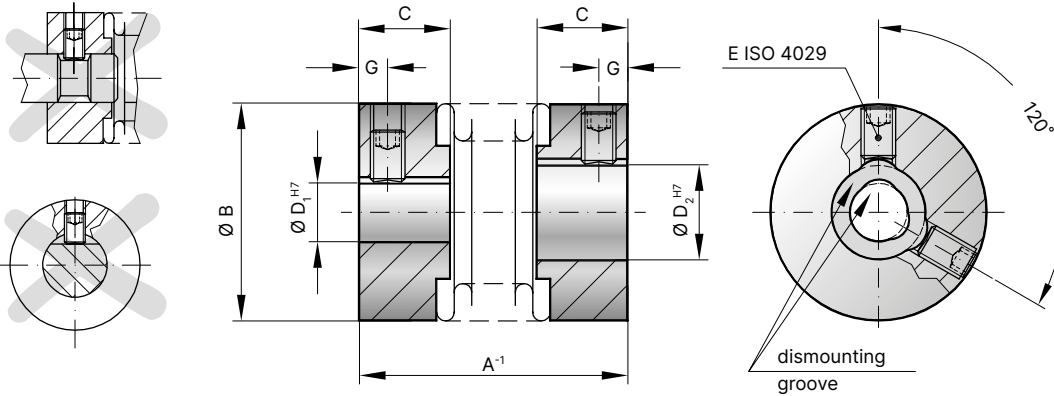

Advantage: Bore diameters above 4mm have an integral dismounting groove, which provides clearance over any burr which may be kicked up by the set screw, eliminating the need for flats on shafts.

Model MK1

Size		0.5	1	5	10	15	20	45	100
Rated torque (Nm)	T_{KN}	0.05	0.1	0.5	1.0	1.5	2.0	4.5	10
Overall length (mm)	A^{-1}	14	20	20 23 26	22 25 28	24 29	26 31 35	37 45	43 53
Outside diameter (mm)	B	6.5	10	15	15	19	25	32	40
Fit length (mm)	C	4	5	6.5	6.5	7.5	11	13	15
Inside diameter possible from \emptyset to $\emptyset H7$ (mm)	$D_{1/2}$	1-3	1-5	3-9	3-9	3-12	3-16	6-22	6-28
Clamping screw ISO 4029		1xM2	1xM2.5	1xM3	1xM3	2xM3	2xM4	2xM5	2xM6
Tightening torque of the fastening screw (Nm)	E	0.35	0.75	1.3	1.3	1.3	2.5	4	6
Distance (mm)	G	1.5	1.8	2	2	2	2.5	3.5	4
Moment of inertia (gcm ²)	J_{ges}	0.1	0.4	1.1 1.2 1.3	1.3 1.8 2	4.7 5.5	15 18 20	65 70	180 220
Approximate weight (g)		1	5	6 6 6	6 7 8	12 14	22 24 26	54 58	106 114
Torsional stiffness (Nm/rad)	C_T	50	70	280 210 170	510 380 320	750 700	1,200 1,300 1,200	7,000 5,000	9,050 8,800
Axial (mm)		0.4	0.4	0.4 0.5 0.6	0.4 0.5 0.6	0.5 0.7	0.5 0.6 0.7 0.7	1 1	1.2
Lateral (mm)	Max. values	0.1	0.15	0.15 0.2 0.25	0.15 0.2 0.25	0.15 0.2	0.15 0.2 0.25 0.2	0.25 0.25	0.2 0.3
Angular (degree)		1	1	1 1.5 2	1 1.5 2	1.5 1.5	1.5 1.5 2 1.5	2 1.5 2	1.5 2

MK2

With clamping hub

0.5 – 10 Nm



Features

- For highly dynamic applications
- Easy installation
- Light weight and low moment of inertia

Material

- **Bellows:** high grade stainless steel
- **Hubs:** aluminium

Design

Two clamping hubs concentrically mounted to flexible bellows.

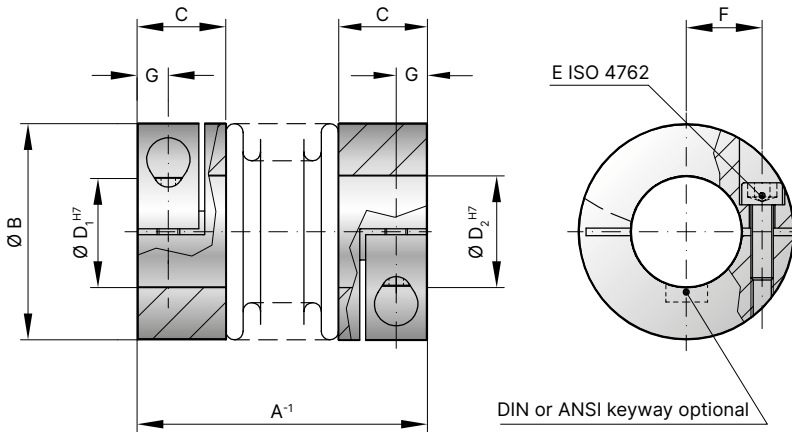

MINIATURE COUPLINGS MK

Optionally available in other materials

Model MK2

Size			5			10			15			20			45			100		
Rated torque (Nm)	T_{KN}		0.5			1.0			1.5			2.0			4.5			10		
Overall length (mm)	A^{-1}		25	28	31	27	30	33	30	35	35	40	44	46	54	50	60			
Outside diameter (mm)	B		15			15			19			25			32			40		
Fit length (mm)	C		9			9			11			13			16			16		
Inside diameter possible from Ø to Ø H7 (mm)	$D_{1/2}$		3-7			3-7			3-8			3-12.7			5-16			5-24		
Fastening screw ISO 4762			M2			M2			M2.5			M3			M4			M4		
Tightening torque of the fastening screw (Nm)	E		0.43			0.43			0.85			2.3			4			4.5		
Distance between centerlines (mm)	F		4.5			4.5			6			8			10			15		
Distance (mm)	G		3			3			3.5			4			5			5		
Moment of inertia (gcm^2)	J_{ges}		2.6	2.8	3	3	3.4	3.6	8.5	9.5	25	27	29	100	108	160	205			
Approximate weight (g)			9	9	9	9	10	11	22	24	36	38	40	74	78	120	130			
Torsional stiffness (Nm/rad)	C_T		280	210	170	510	380	320	750	700	1,200	1,300	1,200	7,000	5,000	9,050	8,800			
Axial (mm)			0.4	0.5	0.6	0.4	0.5	0.6	0.5	0.7	0.5	0.6	0.7	0.7	1	1	1.2			
Lateral (mm)		Max. values	0.15	0.2	0.25	0.15	0.2	0.25	0.15	0.2	0.15	0.2	0.25	0.2	0.25	0.2	0.3			
Angular (degree)			1	1.5	2	1	1.5	2	1.5	1.5	1.5	1.5	2	1.5	2	1.5	2			



With split clamping hub

0.5 – 10 Nm

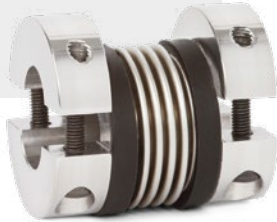

Features

- Mounts laterally
- Allows for pre-alignment of shafts
- Light weight and low moment of inertia

Material

- **Bellows:** high grade stainless steel
- **Hubs:** aluminium

Design

Two fully split clamping hubs, with two screws in each, concentrically mounted to flexible bellows.

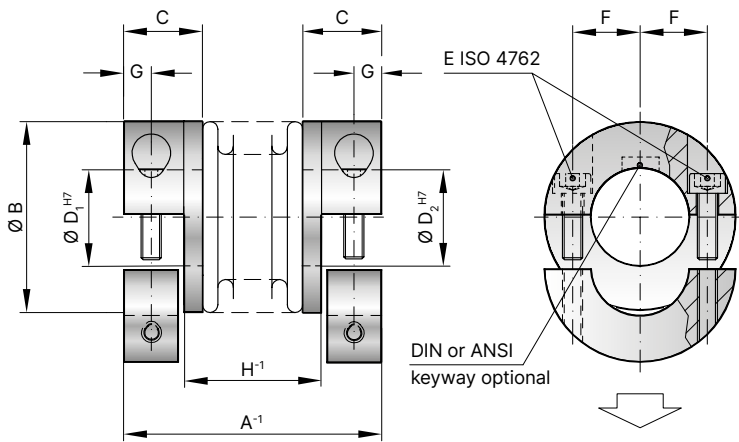

Model MKH

Size		5			10			15		20			45		100		
Rated torque	(Nm)	T_{KN}	0.5			1.0			1.5		2.0			4.5		10	
Overall length	(mm)	A^{-1}	25	28	31	27	30	33	30	35	35	40	44	46	54	50	60
Outside diameter	(mm)	B	15			15			19		25			32		40	
Fit length	(mm)	C	9			9			11		13			16		16	
Inside diameter possible from \emptyset to $\emptyset H7$	(mm)	$D_{1/2}$	3-7			3-7			3-8		3-12.7			5-16		5-24	
Fastening screw ISO 4762		E	M2			M2			M2.5		M3			M4		M4	
Tightening torque of the fastening screw	(Nm)	E	0.43			0.43			0.85		2.3			4		4.5	
Distance between centerlines	(mm)	F	4.5			4.5			6		8			10		15	
Distance	(mm)	G	3			3			3.5		4			5		5	
Distance	(H)	H^{-1}	12	15	18	14	17	20	14.5	19.5	17	22	26	23.5	31.5	27.5	37.5
Moment of inertia	(gcm ²)	J_{ges}	2.6	2.8	3	3	3.4	3.6	8.5	9.5	25	27	29	100	108	160	205
Approximate weight	(g)		9	9	9	9	10	11	22	24	36	38	40	74	78	120	130
Torsional stiffness	(Nm/rad)	C_T	280	210	170	510	380	320	750	700	1,200	1,300	1,200	7,000	5,000	9,050	8,800
Axial	(mm)		0.4	0.5	0.6	0.4	0.5	0.6	0.5	0.7	0.5	0.6	0.7	0.7	1	1	1.2
Lateral	(mm)	Max. values	0.15	0.2	0.25	0.15	0.2	0.25	0.15	0.2	0.15	0.2	0.25	0.2	0.25	0.2	0.3
Angular	(degree)		1	1.5	2	1	1.5	2	1.5	1.5	1.5	1.5	2	1.5	2	1.5	2

MK3

With expanding shaft

0.5 – 10 Nm



Features

- For hollow shaft mounting
- Easy to install
- Light weight and low moment of inertia

Material

- **Bellows:** high grade stainless steel
- **Clamping Hub:** aluminium
- **Expanding shaft:** steel

Design

One clamping hub with one clamping screw, one expanding shaft system, both concentrically mounted to flexible bellows.

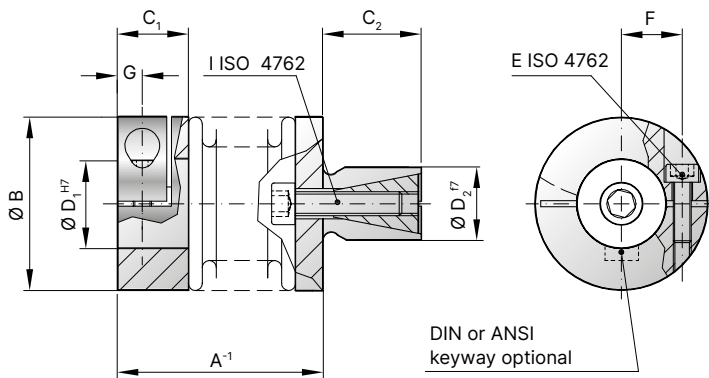

MINIATURE COUPLINGS MK

Model MK3

Size	5			10			15			20			45		100		
Rated torque (Nm)	T_{KN}	0.5			1			1.5			2			4.5		10	
Overall length (mm)	A^{-1}	20	23	26	22	25	28	24	30	27	33	36	36	44	41	51	
Outside diameter (mm)	B	15			15			19			25			32		40	
Fit length (mm)	C_1	9			9			11			13			16		16	
Shaft length (mm)	C_2	10			10			12			12			15		20	
Inside diameter possible from \emptyset to \emptyset H7 (mm)	D_1	3-7			3-7			4-8			4-12.7			5-16		6-24	
Standard shaft possible from \emptyset to \emptyset f7 (mm)	D_2	8-10			8-10			10-14			10-16			14-20		16-24	
Fastening screw ISO 4762		M2			M2			M2.5			M3			M4		M4	
Tightening torque of the fastening screw (Nm)	E	0.43			0.43			0.85			2.3			4		4.5	
Distance between centerlines (mm)	F	4.5			4.5			6			8			10		15	
Distance (mm)	G	3			3			3.5			4			5		5	
Fastening screw ISO 4762		M3			M3			M4			M4			M5		M6	
Tightening torque of the fastening screw (Nm)	I	1.5			1.5			3			4			6.5		11	
Moment of inertia (gcm ²)	$J_{ges.}$	2.6	2.8	3.0	3.0	3.4	3.6	8.5	9.5	25	27	29	100	108	160	205	
Torsional stiffness (Nm/rad)	C_T	280	210	170	510	380	320	750	700	1,200	1,300	1,200	7,000	5,000	9,050	8,800	
Axial (mm)	Max. values	0.4	0.5	0.6	0.4	0.5	0.6	0.5	0.7	0.5	0.6	0.7	0.7	1	1	1.2	
Lateral (mm)		0.15	0.2	0.25	0.15	0.2	0.25	0.15	0.2	0.15	0.2	0.25	0.2	0.25	0.2	0.3	
Angular (degree)		1	1.5	2	1	1.5	2	1.5	1.5	1.5	1.5	2	1.5	2	1.5	2	

MK4

Blind mate with radial set screws

0.5 – 10 Nm



Features

- Easy installation and removal
- Electrically and thermally isolating
- Absolutely backlash free assembly

Material

- **Bellows:** high grade stainless steel
- **Hubs:** aluminium
- **Tapered male segment:** high strength plastic

Design

Two hubs with radial set screws, one of which has a tapered male projection for blind mate connection. Speeds up to 20,000 rpm; over 20,000 rpm with finely balanced version.

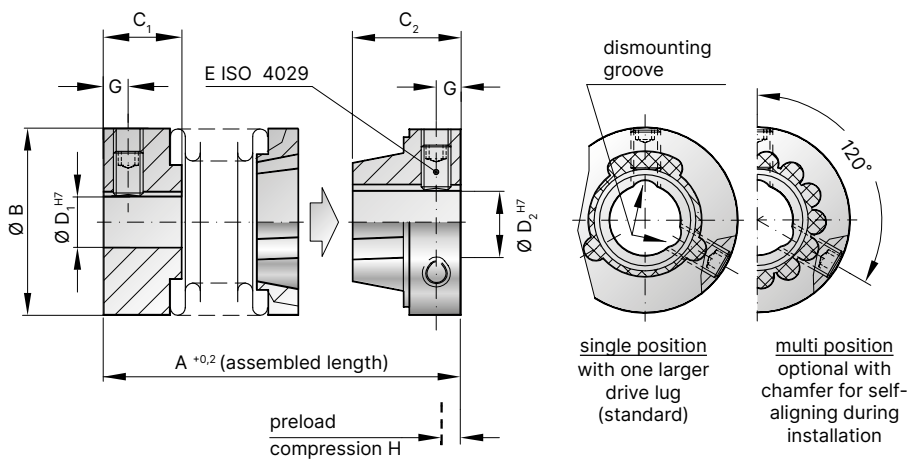

Model MK4

Size	5			15		20			45		100		
Rated torque (Nm)	T_{KN}	0.5			1.5		2			4.5		10	
Overall length (inserted) (mm)	$A^{+0,2}$	22	25	28	26	31	28	33	37	39	47	46	56
Outside diameter (mm)	B	15			19		25			32		40	
Fit length (mm)	C_1	6.5			7.5		11			13		15	
Fit length (mm)	C_2	9			10		11			14		16	
Inside diameter possible from \emptyset to \emptyset H7 (mm)	D_1	3-9			3-12		3-16			6-22		6-28	
Inside diameter possible from \emptyset to \emptyset H7 (mm)	D_2	3-6.35			3-9		3-12.7			6-16		6-20	
Clamping screw ISO 4029		1xM3			2xM3		2xM4			2xM5		2xM6	
Tightening torque of the fastening screw (Nm)	E	1.3			1.3		2.5			4		6	
Distance (mm)	G	2			2		2.5			3.5		4	
Preload compression (mm)	H	0.4			0.5		0.5			0.7		1	
Axial recovery force at max. preload compression (N)		5	3	2	4	3	3	4	3	15	10	25	30
Moment of inertia (gcm ²)	J_{ges}	2.0	2.2	2.5	5.5	6.0	21	23	25	80	85	200	210
Torsional stiffness (Nm/rad)	C_T	280	210	170	750	700	1,200	1,300	1,200	7,000	5,000	9,050	8,800
Axial* (mm)		0.4	0.5	0.6	0.5	0.7	0.5	0.6	0.7	0.7	1	1	1.2
Lateral (mm)	Max. values	0.15	0.2	0.25	0.15	0.2	0.15	0.2	0.25	0.2	0.25	0.2	0.3
Angular (degree)		1	1.5	2	1.5	1.5	1.5	1.5	2	1.5	2	1.5	2

* in addition to maximum pretensioning

MK5

Blind mate with clamping hub

0.5 – 10 Nm



Features

- Easy installation and removal
- Electrically and thermally isolating
- Absolutely backlash free assembly

Material

- **Bellows:** high grade stainless steel
- **Hubs:** aluminium
- **Tapered male segment:** high strength plastic

Design

Two clamping hubs, one of which has a tapered male projection for blind mate connection.

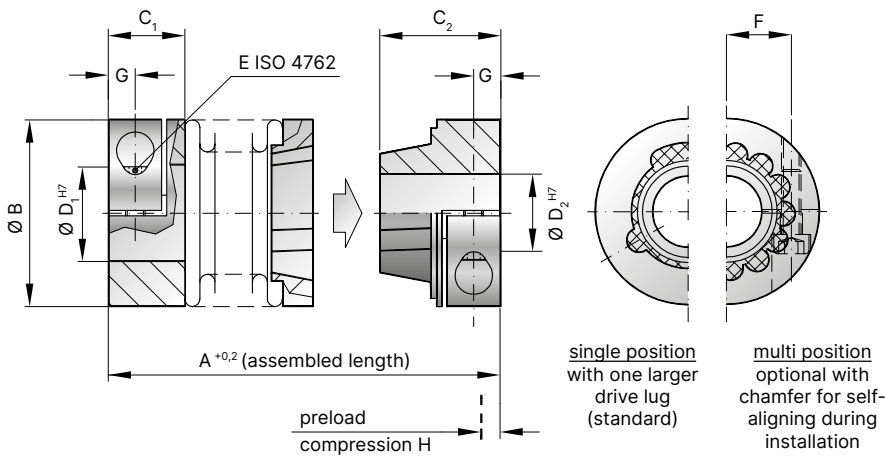

Model MK5

Size			5	15	20	45	100						
Rated torque (Nm)	T_{KN}		0.5	1.5	2	4.5	10						
Overall length (inserted) (mm)	$A^{+0.2}$	27	30	33	34	39	37	43	46	49	57	55	65
Outside diameter (mm)	B		15	19	25	32	40						
Fit length (mm)	C_1		9	11	13	16	16						
Fit length (mm)	C_2		12	14	16	20	21.5						
Inside diameter possible from \emptyset to \emptyset H7 (mm)	D_1		3-7	3-8	3-12.7	5-16	5-24						
Inside diameter possible from \emptyset to \emptyset H7 (mm)	D_2		3-6.35	3-8	3-12.7	5-16	5-20						
Fastening screw ISO 4762			M2	M2.5	M3	M4	M4						
Tightening torque of the fastening screw (Nm)	E		0.43	0.85	2.3	4	4.5						
Distance between centerlines (mm)	F		4.5	6	8	10	15						
Distance (mm)	G		3	3.5	4	5	5						
Preload compression (mm)	H		0.4	0.5	0.5	0.7	1						
Axial recovery force at max. preload compression (N)		5	3	2	4	3	3	4	3	15	10	25	30
Moment of inertia (gcm ²)	J_{ges}	3.0	3.2	3.5	9.0	10	28	30	33	110	120	220	230
Torsional stiffness (Nm/rad)	C_T	280	210	170	750	700	1,200	1,300	1,200	7,000	5,000	9,050	8,800
Axial* (mm)		0.4	0.5	0.6	0.5	0.7	0.5	0.6	0.7	0.7	1	1	1.2
Lateral (mm)	Max. values	0.15	0.2	0.25	0.15	0.2	0.15	0.2	0.25	0.2	0.25	0.2	0.3
Angular (degree)		1	1.5	2	1.5	1.5	1.5	1.5	2	1.5	2	1.5	2

* in addition to maximum pretensioning

MK6

Blind mate with expanding shaft

0.5 – 10 Nm



Features

- Easy installation and removal
- Solution for mismatched bore / shaft diameters
- Absolutely backlash free assembly

Material

- **Bellows:** high grade stainless steel
- **Tapered male segment:** high strength plastic
- **Clamping hub:** aluminium
- **Expanding shaft:** steel

Design

One clamping hub with a tapered male projection for blind mate connection and one expanding shaft system.

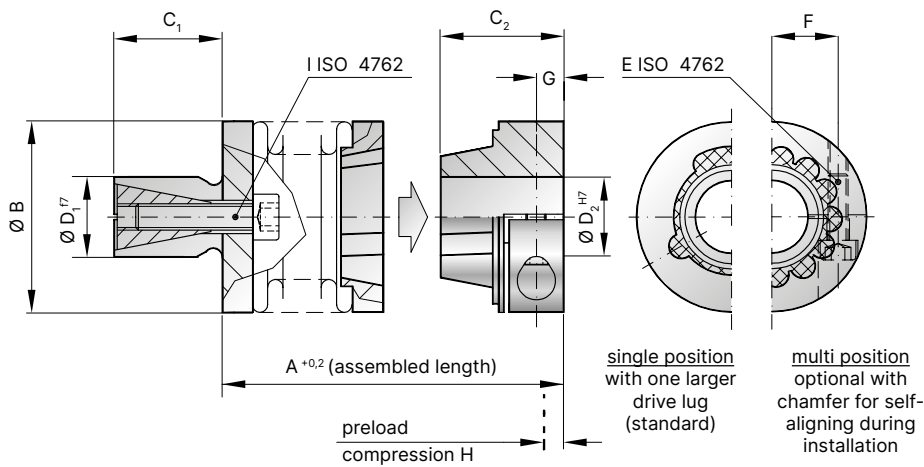

Model MK6

Size	5					15		20			45		100		
Rated torque (Nm)	T_{KN}	0.5					1.5		2			4.5		10	
Overall length (inserted) (mm)	$A^{+0.2}$	21	24	27	27	32	28	34	38	38	46	45	55		
Outside diameter (mm)	B	15					19		25			32		40	
Shaft length (mm)	C_1	10					12		12			15		20	
Fit length (mm)	C_2	12					14		16			20		21.5	
Standard shaft \varnothing f7 (mm)	D_1	8-10					10-14		10-16			14-20		16-24	
Inside diameter possible from \varnothing to \varnothing H7 (mm)	D_2	3-6.35					3-8		3-12.7			5-16		5-20	
Fastening screw ISO 4762		M2					M2.5		M3			M4		M4	
Tightening torque of the fastening screw (Nm)	E	0.43					0.85		2.3			4		4.5	
Distance between centerlines (mm)	F	4.5					6		8			10		15	
Distance (mm)	G	3					3.5		4			5		5	
Preload compression (mm)	H	0.4					0.5		0.5			0.7		1	
Axial recovery force at max. preload compression (N)		5	3	2	4	3	3	4	3	15	10	25	30		
Fastening screw ISO 4762		M3					M4		M4			M5		M6	
Tightening torque of the fastening screw (Nm)	I	1.5					3		4			6.5		11	
Moment of inertia (gcm ²)	J_{ges}	3.0	3.2	3.5	9.0	10	28	30	33	110	120	220	230		
Torsional stiffness (Nm/rad)	C_T	280	210	170	750	700	1,200	1,300	1,200	7,000	5,000	9,050	8,800		
Lateral (mm)	Max. values	0.15	0.2	0.25	0.15	0.2	0.15	0.2	0.25	0.2	0.25	0.2	0.3		
Angular (degree)		1	1.5	2	1.5	1.5	1.5	1.5	2	1.5	2	1.5	2		

MKS

With conical clamping ring

4.5 – 15 Nm
High Speed



Features

- For high speeds
- Self centering conical clamping ring design
- High balancing grade

Material

- **Bellows:** high grade stainless steel
- **Hubs and clamping rings:** aluminium

Design

Two hubs with conical clamping ring and three or four screws.
Maximum speed up to 120,000 rpm.

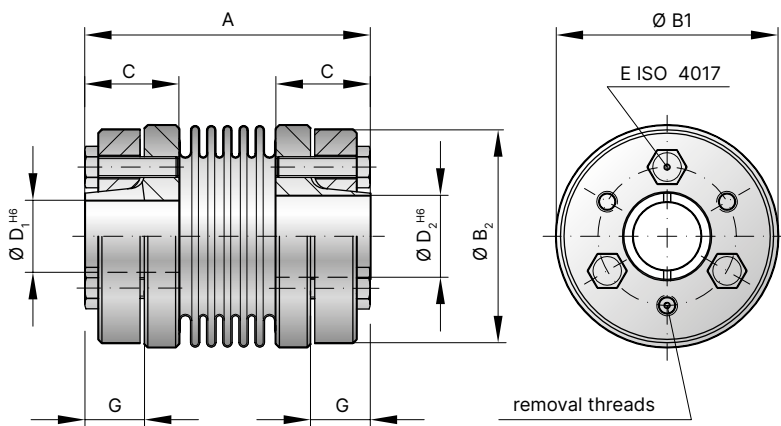

MINIATURE
COUPLINGS MK

Model MKS

Size			45	100	150
Rated torque	(Nm)	T_{KN}	4.5	10	15
Overall length	(mm)	A	42	48	53
Outside diameter	(mm)	B_1	32	40	49
Outside diameter of hub	(mm)	B_2	30	38	46
Fit length	(mm)	C	14	16	20
Inside diameter possible from \emptyset to \emptyset H6	(mm)	$D_{1/2}$	6-10	8-14	10-19
Fastening screw ISO 4017 (mm)			3x M3	4x M3	8x M3
Tightening torque of the fastening screw	(Nm)	E	1.3	1.3	1.3
Distance	(mm)	G	8.5	9.5	13
Moment of inertia	(gcm ²)	$J_{ges.}$	65	226	561
Approximate weight	(g)		51	103	171
Torsional stiffness	(Nm/rad)	C_T	7,000	9,050	23,000
Axial	(mm)		0.5	0.75	0.75
Lateral	(mm)	Max. values	0.5	0.75	0.1
Angular	(degree)		0.5	0.5	0.05*

For speeds beyond 50,000 rpm use reduced misalignment values marked with *

FK1

Microflex with radial set screws

1 Ncm



Features

- Very small dimensions
- Backlash free
- Vibration damping

Material

- **Flex element:** High strength Polyamide
- **Hubs:** Stainless steel

Design

Two hubs with set screws mounted to a flex beam segment. Operational from -35°C to +80° C. Speeds up to 20,000 rpm

Special solution

Effective outside diameter can be reduced to 4.5mm through the use of M2×1.5 mm screws.

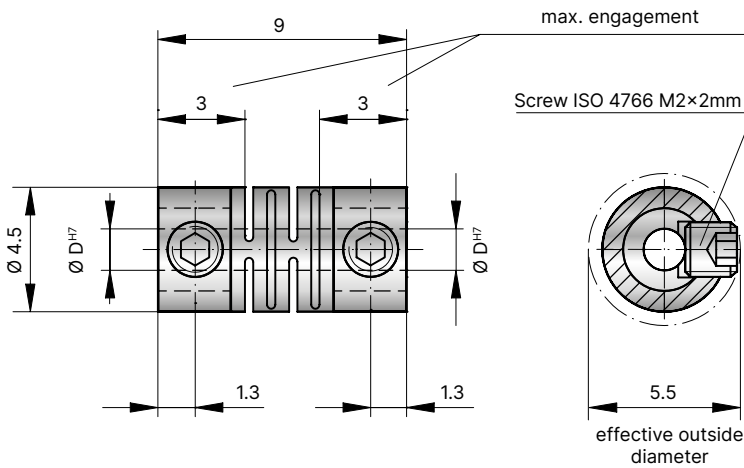

Coupling assembly and mounting

The screw threads through the clamping ring, through a slot in the flexible segment, and down onto the shaft, securing the entire assembly. Including a flat on the shaft can improve torque transmission.

Caution: Always use a precisely calibrated torque wrench during installation.

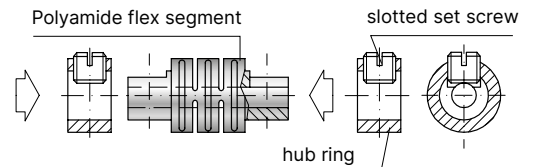

Model FK1/001/9

Size

Rated torque	(Ncm)	T_{KN}	1
Bore diameter H7	(mm)	D_1, D_2	1.5 / 1.5 or 2 / 1.5 additional bore diameters available upon request
Moment of inertia	(gcm ²)	$J_{ges.}$	5.39
Approximate weight	(g)		0.47
Torsional stiffness	(Ncm/rad)	C_T	23 (measured at +20° C)
Axial	(mm)		0.2
Lateral	(mm)	Max. values	0.1
Angular	(degree)		1.5

Dismounting

For dismounting, simply loosen the set screws and remove the coupling from the shafts.

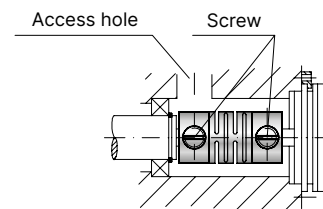

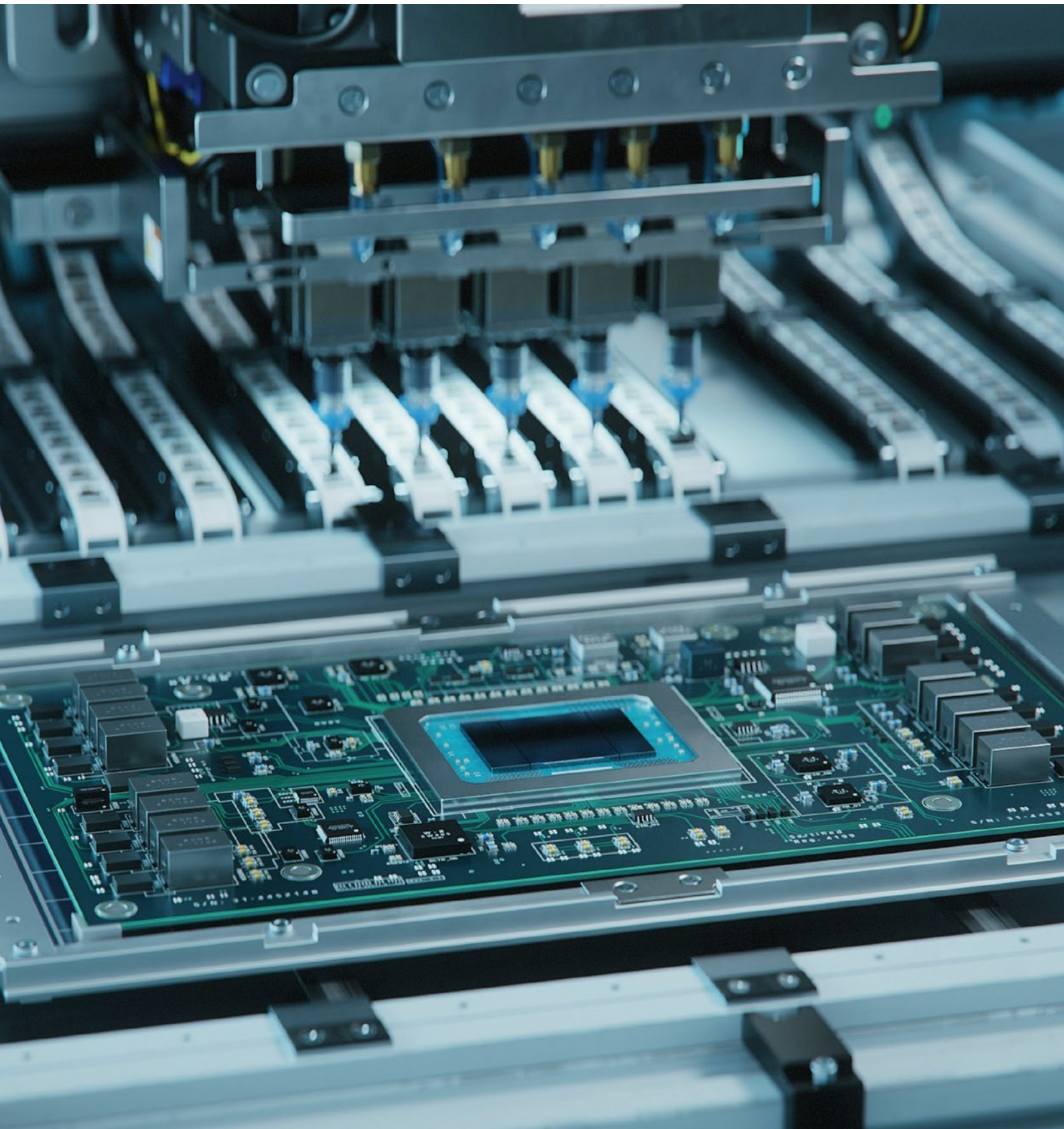



Backlash free servo disc pack couplings **25 – 100 Nm**



SERVO DISC PACK
COUPLINGS SCL

Areas of application

For dynamic drive applications in

- + Machine tools
- + Printing applications
- + Extruders
- + Test stands

Service life

R+W servo disc pack couplings are fatigue resistant and wear free for an infinite service life, as long as the technical limits are not exceeded.

Temperature range

-30°C to +130°C

Fit clearance

Overall shaft / hub clearance of 0.01 - 0.05 mm

Special solutions

Available on request.

Rotational speed

Standard up to 10,000 rpm.





ATEX (Optional)

Available on request.

Ordering Example	SCL2	25	D	18	20	XX
Model	●					Special designation only (e.g. balanced G2.5)
Size		●				
System			●			
Bore Ø D1 H7				●		
Bore Ø D2 H7					●	

For custom features place an XX at the end of the part number and describe the special requirements (e.g. SCL2 / 25 / D / 18 / 20 / XX)

Backlash free servo disc pack couplings 25 – 100 Nm

Model	Features	Page
<p>SCL2 S</p> 	<p>With clamping hub single flex coupling 25 - 100 Nm</p> <ul style="list-style-type: none"> • Very high torsional stiffness • Compact design • Low moment of inertia 	56
<p>SCL2 D</p> 	<p>With clamping hub double flex coupling 25 - 100 Nm</p> <ul style="list-style-type: none"> • High torsional stiffness • Low moment of inertia • Lateral misalignment compensation 	57
<p>SCL3 S</p> 	<p>With conical clamping system single flex coupling 25 - 100 Nm</p> <ul style="list-style-type: none"> • Very high concentricity • High clamping pressure • Low moment of inertia 	58
<p>SCL3 D</p> 	<p>With conical clamping system double flex coupling 25 - 100 Nm</p> <ul style="list-style-type: none"> • High concentricity • High clamping pressure • High torsional stiffness 	59

SCL2 S

With clamping hub single flex coupling

25 - 100 Nm



Features

- Very high torsional stiffness
- Compact design
- Low moment of inertia

Material

- **Disc packs:** highly elastic steel
- **Hubs and spacer:** aluminium

Design

Two precision machined coupling hubs and precision spacer mounted to the disc packs by means of high strength screws and spacers for frictional clamping of the assembly. Also available as split clamping hub.

S = Single flex coupling

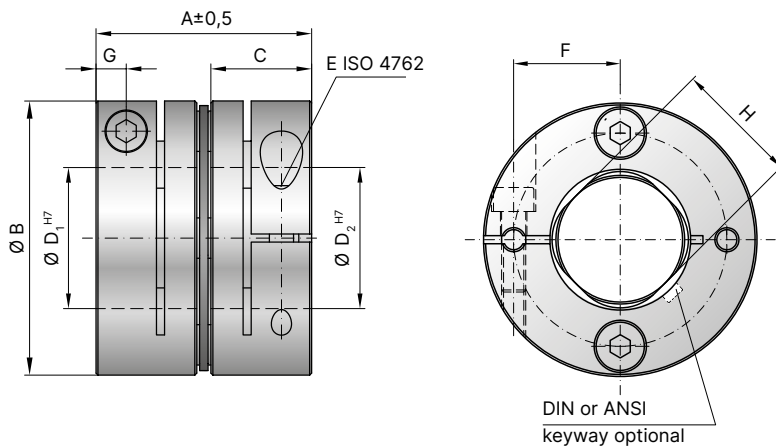

Modell SCL2 S

Size			25	40	60	100
Rated torque	(Nm)	T_{KN}	25	40	60	100
Maximum torque	(mm)	T_{Kmax}	37.5	60	90	150
Coupling length	(mm)	A	43.6	50.9	53.5	68.7
Outside diameter	(mm)	B	56	63	68	82
Fit length	(mm)	C	20.5	24	25	30
Bore diameter H7	(mm)	D_1 / D_2	15-30	16-30	25-35	26-40
Fastening screw			M5	M6	M6	M8
Tightening torque	(Nm)	E	8	15	15	30
Distance	(mm)	F	22	23	26.5	28
Distance	(mm)	G	6	7.5	7.5	8.5
Shaft diameter limitation	(mm)	H	26	-	31	38
Moment of inertia	(10^{-3} kgm^2)	J_{ges}	0.095	0.182	0.260	0.706
Weight	(kg)		0.192	0.304	0.363	0.694
Torsional stiffness	(Nm/rad)	C_T	46,000	58,000	82,000	157,000
Axial displacement	± (mm)		0.4	0.42	0.5	0.5
Lateral displacement	± (mm)	Max. values	-	-	-	-
Angular displacement	± (degree)		1	1	1	1
Max. speed	(1/min)				10,000	

SCL2 D

With clamping hub double flex coupling

25 – 100 Nm



Features

- High torsional stiffness
- Low moment of inertia
- Lateral misalignment compensation

Material

- **Disc packs:** highly elastic steel
- **Hubs and spacer:** aluminium

Design

Two precision machined coupling hubs and precision spacer mounted to the disc packs by means of high strength screws and spacers for frictional clamping of the assembly. Also available as split clamping hub.

D = Double flex coupling

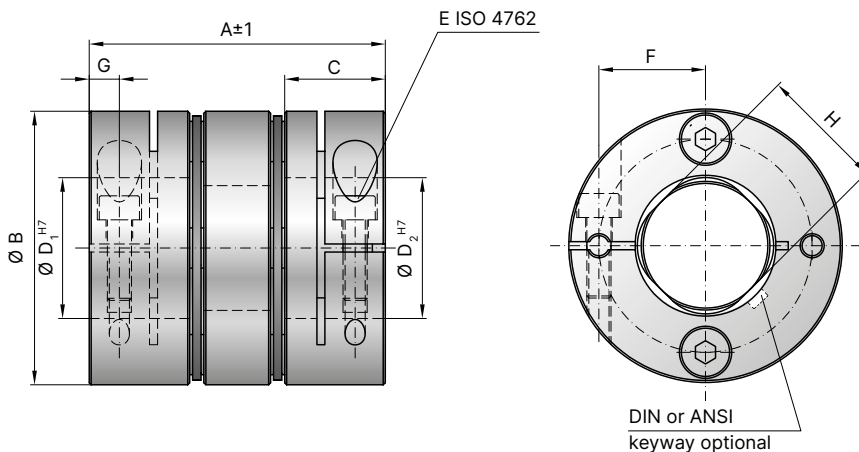

Model SCL2 D

Size			25	40	60	100
Rated torque	(Nm)	T_{KN}	25	40	60	100
Maximum torque	(mm)	T_{Kmax}	37.5	60	90	150
Coupling length	(mm)	A	60.2	69.3	73.6	98.8
Outside diameter	(mm)	B	56	63	68	82
Fit length	(mm)	C	20.5	24	25	30
Bore diameter H7	(mm)	D_1 / D_2	15-30	16-30	25-35	26-40
Fastening screw			M5	M6	M6	M8
Tightening torque	(Nm)	E	8	15	15	30
Distance	(mm)	F	22	23	26.5	28
Distance	(mm)	G	6	7.5	7.5	8.5
Shaft diameter limitation	(mm)	H	26	–	31	38
Moment of inertia	(10^{-3} kgm^2)	J_{ges}	0.138	0.256	0.373	1.036
Weight	(kg)		0.284	0.428	0.531	1.022
Torsional stiffness	(Nm/rad)	C_T	23,000	29,000	41,000	78,500
Axial displacement	± (mm)		0.81	0.85	1	1.15
Lateral displacement	± (mm)	Max. values	0.29	0.32	0.35	0.53
Angular displacement	± (degree)		2	2	2	2
Max. speed	(1/min)		10,000			

SCL3 S

With conical clamping system single flex coupling

25 – 100 Nm



Features

- Very high concentricity
- High clamping pressure
- Low moment of inertia

Material

- **Disc packs:** highly elastic spring steel
- **Hubs and spacer:** aluminium

Design

Two precision machined coupling hubs and precision spacer mounted to the disc packs by means of high strength screws and spacers for frictional clamping of the assembly.

S = Single flex coupling

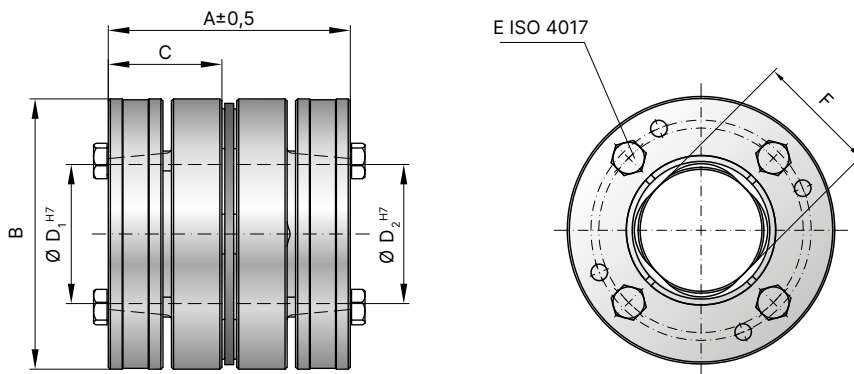

Model SCL3 S

Size			25	40	60	100
Rated torque	(Nm)	T_{KN}	25	40	60	100
Maximum torque	(mm)	T_{Kmax}	37.5	60	90	150
Coupling length	(mm)	A	56.6	56.9	57.5	73.7
Outside diameter	(mm)	B	56	63	68	82
Fit length	(mm)	C	27	27	27	32.5
Bore diameter H7	(mm)	D_1 / D_2	18-28	20-30	27-35	24-40
Fastening screw		E	M5	M5	M5	M5
Tightening torque	(Nm)		5.5	6	6	6
Shaft diameter limitation	(mm)	F	26	-	31	38
Moment of inertia	(10^{-3} kgm^2)	J_{ges}	0.144	0.230	0.310	0.837
Weight	(kg)		0.299	0.384	0.435	0.835
Torsional stiffness	(Nm/rad)	C_T	46,000	58,000	82,000	157,000
Axial displacement	± (mm)		0.4	0.42	0.5	0.5
Lateral displacement	± (mm)	Max. values	-	-	-	-
Angular displacement	± (degree)		1	1	1	1
Max. speed	(1/min)		10,000			

SCL3 D

With conical clamping system double flex coupling

25 – 100 Nm



Features

- High concentricity
- High clamping pressure
- High torsional stiffness

Material

- **Disc packs:** highly elastic spring steel
- **Hubs and spacer:** aluminium

Design

Two precision machined coupling hubs and precision spacer mounted to the disc packs by means of high strength screws and spacers for frictional clamping of the assembly.

D = Double flex coupling

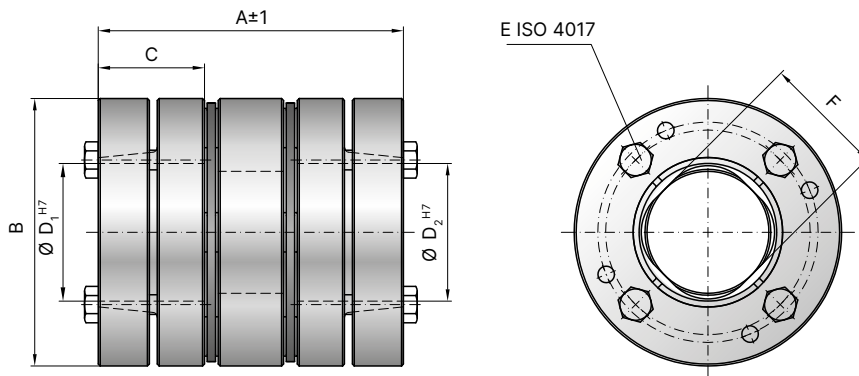

Model SCL3 D

Size			25	40	60	100
Rated torque	(Nm)	T_{KN}	25	40	60	100
Maximum torque	(mm)	T_{Kmax}	37.5	60	90	150
Coupling length	(mm)	A	73.2	75.3	77.6	103.8
Outside diameter	(mm)	B	56	63	68	82
Fit length	(mm)	C	27	27	27	32.5
Bore diameter H7	(mm)	D_1 / D_2	18-28	20-30	27-35	24-40
Fastening screw		E	M5	M5	M5	M5
Tightening torque	(Nm)		5.5	6	6	6
Shaft diameter limitation	(mm)	F	26	-	31	38
Moment of inertia	(10^{-3} kgm^2)	J_{ges}	0.187	0.304	0.422	1.170
Weight	(kg)		0.390	0.508	0.603	1.156
Torsional stiffness	(Nm/rad)	C_T	23,000	29,000	41,000	78,500
Axial displacement	± (mm)	Max. values	0.81	0.85	1	1.15
Lateral displacement	± (mm)		0.29	0.32	0.35	0.53
Angular displacement	± (degree)		2	2	2	2
Max. speed	(1/min)		10,000			



EK

SP

Backlash free elastomer couplings Servomax[®] 0.5 – 25,000 Nm

Areas of application

for vibration damping torque transmission in:

- + Packaging machinery
- + Pump drives
- + Machine tools
- + Lift systems
- + Conveyors
- + Labeling machinery

Service life

When properly selected, handled, and installed, these couplings are maintenance free with infinite service life.

Fit clearance

Overall shaft / hub clearance of 0.01 - 0.05 mm

Features

Elastomer is press fit for zero backlash; standard versions are electrically isolating.

Special solutions

Various materials, tolerances, dimensions and performance ratings available for custom applications on request.

ATEX (Optional)

Available on request.

Ordering Example	EK2	20	A	8	10	XX
Model	•					Special designation only (e.g. special bore tolerance).
Size		•				
Elastomer insert type			•			
Bore Ø D1 H7				•		
Bore Ø D2 H7					•	





For custom features place an XX at the end of the part number and describe the special requirements (e.g. EK2 / 20 / A / 8 / 10 / XX)



EK

SP

Backlash free elastomer couplings

Servomax® 0.5 – 25,000 Nm

Model	Features	Page
 <p>EK1</p>	<p>With keyway connection 0.5 – 25,000 Nm</p> <ul style="list-style-type: none"> • Press fit design • Readily modified for custom dimensions 	66-67
 <p>EK2</p>	<p>With clamping hub 6 – 2,150 Nm</p> <ul style="list-style-type: none"> • High concentricity • Backlash free • Easy mounting 	68
 <p>EKL</p>	<p>With clamping hub 0.5 - 2,150 Nm</p> <ul style="list-style-type: none"> • Compact design • Low moment of inertia • Easy mounting 	69
 <p>EKH</p>	<p>With split clamping hub 4 – 25,000 Nm</p> <ul style="list-style-type: none"> • For lateral installation • Allows for pre-aligned shafts • Easy mounting 	70-71
 <p>EK6</p>	<p>With conical clamping ring 4 – 25,000 Nm</p> <ul style="list-style-type: none"> • High concentricity • High clamping pressure • Self centering hub design • Allows for axial installation 	72-73

Model	Features	Page
 <p data-bbox="148 667 199 696">SP6</p>	<p data-bbox="592 640 1027 672">For high speed spindle applications</p> <p data-bbox="592 680 762 710">60 - 2,150 Nm</p> <ul data-bbox="592 719 975 857" style="list-style-type: none"> <li data-bbox="592 719 842 748">• Very high precision <li data-bbox="592 757 890 786">• Very high concentricity <li data-bbox="592 795 852 824">• High clamping force <li data-bbox="592 833 975 862">• Symmetrically machined hubs 	74
 <p data-bbox="148 969 199 999">EK7</p>	<p data-bbox="592 943 855 974">With expanding shaft</p> <p data-bbox="592 983 746 1012">2 – 2,150 Nm</p> <ul data-bbox="592 1021 1098 1122" style="list-style-type: none"> <li data-bbox="592 1021 922 1050">• For hollow shaft mounting <li data-bbox="592 1059 1098 1088">• Expanding shaft through axial tightening <li data-bbox="592 1097 1027 1126">• Short body length after installation 	75
 <p data-bbox="148 1234 199 1263">EKZ</p>	<p data-bbox="592 1211 839 1243">Intermediate spacer</p> <p data-bbox="592 1252 746 1281">2 – 2,150 Nm</p> <ul data-bbox="592 1290 919 1386" style="list-style-type: none"> <li data-bbox="592 1290 919 1319">• High lateral misalignment <li data-bbox="592 1328 786 1357">• Easy to mount <li data-bbox="592 1366 831 1395">• Vibration damping 	76

General informations R+W elastomer couplings

Sizes 2 – 800

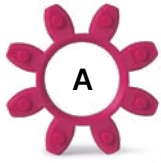

Shore hardness
98 Sh A

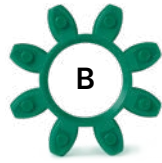

Shore hardness
64 Sh D

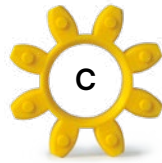

Shore hardness
80 Sh A



Shore hardness
65 Sh D

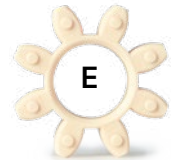

Shore hardness
64 Sh D

Sizes 2.500 – 9.500

The coupling includes 5x elastomer segments

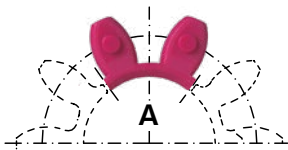

Shore hardness 98 Sh A

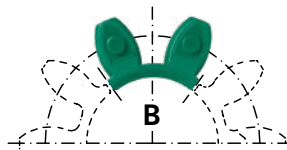

Shore hardness 64 Sh D

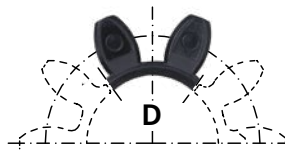

Shore hardness 65 Sh D

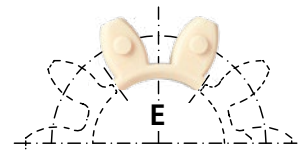

Shore hardness 64 Sh D

Description of the elastomer inserts

Type	Shore hardness	Color	Material	Relative damping (Ψ)	Temperature range	Features
A	98 Sh A	red	TPU	0.4 - 0.5	-30°C to +100°C	high damping
B	64 Sh D	green	TPU	0.3 - 0.45	-30°C to +120°C	high torsional stiffness
C	80 Sh A	yellow	TPU	0.3 - 0.4	-30°C to +100°C	very high damping
D*	65 Sh D	black	TPU	0.3 - 0.45	-10°C to + 70°C	electrically conductive
E	64 Sh D	beige	Hytrel	0.3 - 0.45	-50°C to +150°C	temperature resistant

* The electrical conductivity of the elastomer material is to prevent the electrostatic charging of the elastomer coupling system, to reduce the risk of sparking in operation. ATEX technical data is available upon request. The values of the relative damping were determined at 10 Hz and +20° C.

Sizes EK

Size*	2			5			10			20			60			
Type (Elastomer insert)		A	B	C	A	B	C	A	B	C	A	B	C	A	B	C
Static torsional stiffness (Nm/rad)	C_T	50	115	17	150	350	53	260	600	90	1,140	2,500	520	3,290	9,750	1,400
Dynamic torsional stiffness (Nm/rad)	C_{Tdyn}	100	230	35	300	700	106	541	1,650	224	2,540	4,440	876	7,940	11,900	2,072
Lateral (mm)	Max. values	0.08	0.06	0.2	0.08	0.06	0.2	0.1	0.08	0.22	0.1	0.08	0.25	0.12	0.1	0.25
Angular (degree)		1	0.8	1.2	1	0.8	1.2	1	0.8	1.2	1	0.8	1.2	1	0.8	1.2
Axial (mm)		±1			±1			±1			±1,5			±1,5		

Size*	150			300			400			450			600			
Type (Elastomer insert)		A	B	C	A	B	C	A	B	C	A	B	C	A	B	C
Static torsional stiffness (Nm/rad)	C_T	4,970	10,600	2,000	12,400	18,000	3,000	14,200	24,200	3,650	15,100	27,000	4,120	25,000	49,100	7,550
Dynamic torsional stiffness (Nm/rad)	C_{Tdyn}	13,400	29,300	3,590	23,700	40,400	6,090	43,200	66,300	7,050	55,400	81,200	11,600	63,600	136,800	21,200
Lateral (mm)	Max. values	0.15	0.12	0.3	0.18	0.14	0.35	0.2	0.16	0.35	0.2	0.18	0.35	0.22	0.18	0.36
Angular (degree)		1	0.8	1.2	1	0.8	1.2	1	0.8	1.2	1	0.8	1.2	1	0.8	1.2
Axial (mm)		±1,8			±2			±2			±2					

Size*	800			2.500		4.500		9.500		
Type (Elastomer insert)		A	B	C	A	B	A	B	A	B
Static torsional stiffness (Nm/rad)	C_T	41,300	66,080	10,320	87,600	109,000	167,000	372,000	590,000	670,000
Dynamic torsional stiffness (Nm/rad)	C_{Tdyn}	82,600	180,150	28,600	175,000	216,000	337,000	743,000	1,180,000	1,340,000
Lateral (mm)	Max. values	0.25	0.2	0.4	0.5	0.3	0.5	0.3	0.6	0.4
Angular (degree)		1	0.8	1.2	1.5	1	1.5	1	1.5	1
Axial (mm)		±2			±3		±3		±4	

Static torsional stiffness at 50% T_{KN} Dynamic torsional stiffness at T_{KN}

* Note: The technical values for elastomer inserts D and E correspond to the values for B, due to the identical Shore hardness.

EK1

With keyway connection

0.5 - 2,150 Nm



Features

- Press fit design
- Readily modified for custom dimensions
- Low backlash (keyway)

Material

- **Hubs:** up to size 600 high strength aluminum; size 800 steel
- **Elastomer:** wear resistant thermally stable TPU

Design

Two concentrically machined hubs with curved jaws, keyways, and set screws.

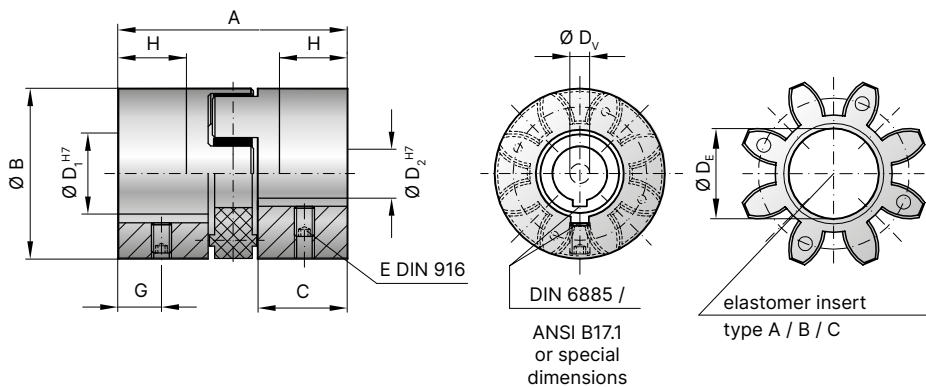

Optional:
Conical bores for
Fanuc motors and
other tapered shafts
available.

Model EK1

Size	2			5			10			20			60			150			300			400			450			600			800		
Type (Elastomer insert)	A	B	C	A	B	C	A	B	C	A	B	C	A	B	C	A	B	C	A	B	C	A	B	C	A	B	C	A	B	C	A	B	C
Rated torque (Nm) T_{KN}	2	2.4	0.5	9	12	2	12.5	16	4	17	21	6	60	75	20	160	200	42	325	405	84	410	520	90	530	660	95	700	840	150	950	1,100	240
Max. torque (Nm) T_{Kmax}	4	4.8	1	18	24	4	25	32	6	34	42	12	120	150	35	320	400	85	650	810	170	820	1,040	180	1,060	1,350	190	1,400	1,680	300	1,900	2,150	400
Overall length (mm)	A	20		34			35			66			78			90			114			120			126			147			162		
Outside diameter (mm) B/B_1	15			25			32			42			56			66.5			82			95			102			120			136.5		
Mounting length (mm)	C	6.5		12			12			25			30			35			45			46			50			57			65		
Inside diameter (pilot bored) (mm) D_v	3			4			6			7			9			14			16			20			22			25			29		
Inside diameter range H7 (mm) $D_{1/2}$	3 - 9			6 - 15			6 - 18			8 - 25			12 - 32			19 - 38			20 - 45			25-50			28 - 60			30-70			32 - 80		
Inside diameter of elastomer (mm) D_e	6.2			10.2			14.2			19.2			26.2			29.2			36.2			43			46.2			55			60.5		
Set screws (DIN 916) E	see table (depending on bore Ø)**																																
Distance (mm) G	3			5			6			9			11			12			15			16			17			23			30		
Possible shortening length (mm) H	4			6			6			19			22			26			32			35			37			40			43		
Moment of inertia per hub (per hub) J_1/J_2 (10^{-3} kgm ²)	0.0001			0.001			0.003			0.02			0.06			0.2			0.6			1.1			1.5			3.5			19		
Approx. weight (kg)	0.008			0.03			0.08			0.15			0.35			0.7			1.4			1.9			2.3			3.7			15.5		
Speed standard (min ⁻¹)	15,000			15,000			13,000			12,500			11,000			10,000			9,000			8,500			8,000			6,800			4,000		
Speed balanced (10^3 min ⁻¹)	60	67	45	57	65	43	53	63	40	45	60	35	31	31	25	22	26	18	22	26	16	17	18	13	16	17	12	14	14	10	13	13	8

For information on shaft misalignment, torsional stiffness, and other details about the elastomer inserts see pages 64.

** set screw size

D_1/D_2	- Ø 10	Ø 10.1 - 12	Ø 12,1 - 30	Ø 30.1 - 60	Ø 60.1 - 95	Ø 95.1 - 130	Ø 130.1 - 170
E	M4	M4	M5	M8	M10	M12	M16

EK1

With keyway connection

1,950 – 25,000 Nm



Features

- Press fit design
- Readily modified for custom dimensions
- Low backlash (keyway)

Material

- **Hubs:** GGG40
- **Elastomer:** wear resistant thermally stable TPU

Design

Two concentrically machined hubs with curved jaws, keyways, and set screws. Elastomer insert consist of 5 segments.

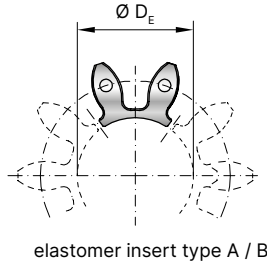
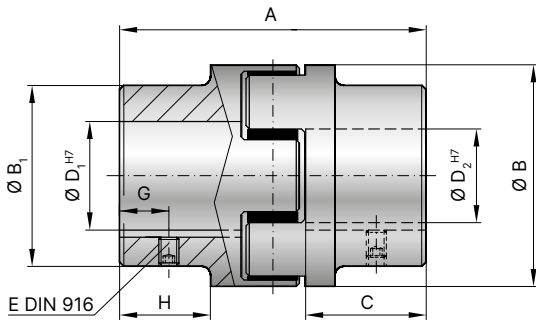

Model EK1

Serie		2,500		4,500		9,500	
Type (Elastomer insert)		A	B	A	B	A	B
Rated torque	(Nm) T_{KN}	1,950	2,450	5,000	6,200	10,000	12,500
Max. torque	(Nm) T_{Kmax}	3,900	4,900	10,000	12,400	20,000	25,000
Overall length	(mm) A	213		272		341	
Outside diameter	(mm) B/B ₁	160 / 154		225 / 190		290 / 240	
Mounting length	(mm) C	88		113		142	
Inside diameter (pilot bored)	(mm) D _v	28		39		49	
Inside diameter range H7	(mm) D _{1/2}	30 - 95		40 - 130		50 - 170	
Inside diameter of elastomer	(mm) D _E	80		111		145	
Set screws (DIN 916)	E	see table (depending on bore Ø)**					
Distance	(mm) G	25		30		40	
Possible shortening length	(mm) H	69		89		110	
Moment of inertia per hub	(10 ⁻³ kgm ²) J ₁ /J ₂	40		147		480	
Approx. weight	(kg)	12.5		25		53	
Speed standard	(min ⁻¹)	3,500		3,000		2,000	
Speed balanced	(10 ³ min ⁻¹)	10	10	8	8	6.5	6.5

For information on shaft misalignment, torsional stiffness, and other details about the elastomer inserts see pages 64.

EK2

With clamping hub

6 – 2,150 Nm



Features

- Easy mounting
- Highly concentric assembly
- Vibration damping

Material

- **Hubs:** up to size 600 high strength aluminum; size 800 steel
- **Elastomer:** wear resistant thermally stable TPU

Design

Two concentrically machined hubs with curved jaws and clamping screws.

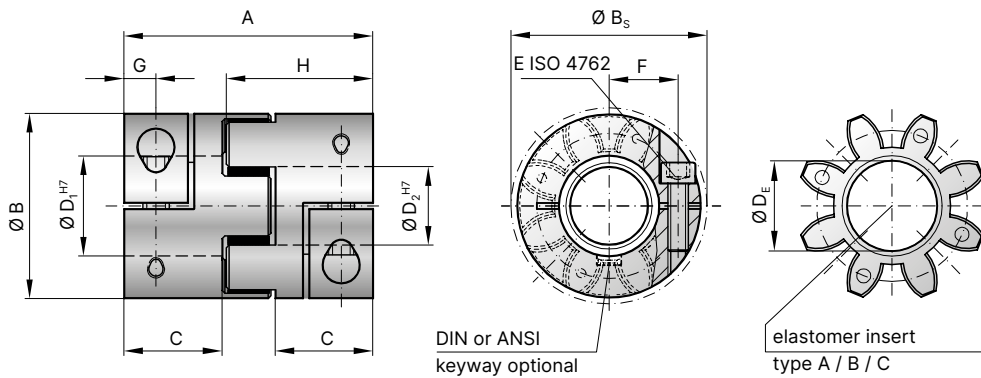

Model EK2

Size		20			60			150			300			400			450			600			800		
Type (Elastomer insert)		A	B	C	A	B	C	A	B	C	A	B	C	A	B	C	A	B	C	A	B	C	A	B	C
Rated torque (Nm)	T_{KN}	17	21	6	60	75	20	160	200	42	325	405	84	410	520	90	530	660	95	700	840	150	950	1,100	240
Max. torque (Nm)	T_{Kmax}	34	42	12	120	150	35	320	400	85	650	810	170	820	1,040	180	1,060	1,350	190	1,400	1,680	300	1,900	2,150	400
Overall length (mm)	A	66			78			90			114			118			126			141			162		
Outside diameter (mm)	B	42			56			66.5			82			95			102			120			136.5		
Outside diameter with screw head (mm)	B_s	44.5			57			68			85			96			105			122.5			139		
Mounting length (mm)	C	25			30			35			45			46			50			54			65		
Inside diameter range H7 (mm)	$D_{1/2}$	8 - 25			12 - 32			19 - 36			20 - 45			25-50			28 - 60			30-70			35 - 80		
Inside diameter of elastomer (mm)	D_E	19.2			26.2			29.2			36.2			43			46.2			55			60.5		
Clamping screw (ISO 4762)		M5			M6			M8			M10			M12			M12			M12			M16		
Tightening torque of the clamping screw (Nm)	E	8			15			35			70			120			120			120			290		
Distance between centers (mm)	F	15.5			21			24			29			32			38			47			50.5		
Distance (mm)	G	8.5			10			12			15			15			17.5			20			23		
Hub length (mm)	H	39			46			52.5			66			69			73			83			93.5		
Moment of inertia per hub (10^{-3} kgm^2)	J_1, J_2	0.02			0.08			0.1			0.5			1			1.4			3.2			17		
Approx. weight (kg)		0.2			0.35			0.6			1.1			1.5			2			3.2			12.7		
Speed standard (min^{-1})		12,500			11,000			10,000			9,000			8,500			8,000			6,800			4,000		
Speed balanced (10^3 min^{-1})		45	60	35	31	31	25	22	26	18	22	26	16	17	18	13	16	17	12	14	14	10	13	13	8

For information on shaft misalignment, torsional stiffness, and other details about the elastomer inserts see pages 64.

EKL

Compact version with clamping hub

0.5 – 2,150 Nm



Features

- Short overall length
- Easy mounting
- Vibration damping

Material

- **Hubs:** up to size 600 high strength aluminum; size 800 steel
- **Elastomer:** wear resistant thermally stable TPU

Design

Two concentrically machined hubs with curved jaws and clamping screws.

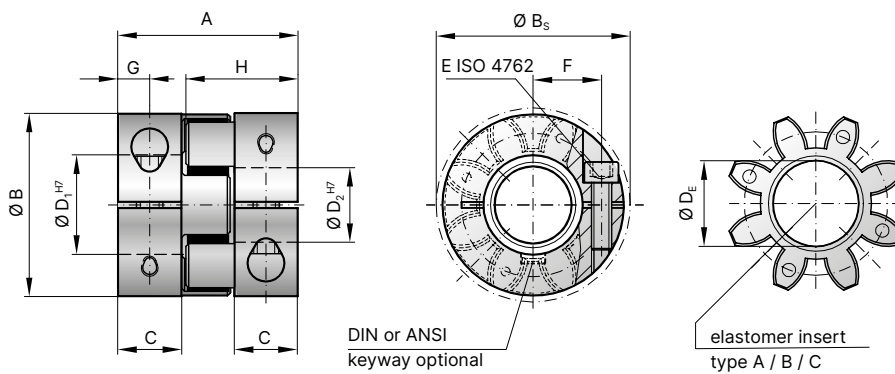

Model EKL

Size		2			5			10			20			60			150			300			400			450			600			800		
Type (Elastomer insert)		A	B	C	A	B	C	A	B	C	A	B	C	A	B	C	A	B	C	A	B	C	A	B	C	A	B	C	A	B	C	A	B	C
Rated torque (Nm)	T _{RN}	2	2.4	0.5	9	12	2	12.5	16	4	17	21	6	60	75	20	160	200	42	325	405	84	410	520	90	530	660	95	700	840	150	950	1,100	240
Max. torque (Nm)	T _{Kmax}	4	4.8	1	18	24	4	25	32	6	34	42	12	120	150	35	320	400	85	650	810	170	820	1,040	180	1,060	1,350	190	1,400	1,680	300	1,900	2,150	400
Overall length (mm)	A	20	26	32	50	58	62	86	90	94	111	123																						
Outside diameter (mm)	B	16	25	32	42	56	66.5	82	95	102	120	136.5																						
Outside diameter with screw head (mm)	B _s	17	25	32	44.5	57	68	85	98	105	122	139																						
Mounting length (mm)	C	6	8	10.3	17	20	21	31	32	34	40	46																						
Inside diameter range H7 (mm)	D _{1/2}	3 - 8	4 - 12.7	4 - 16	8 - 25	12 - 32	19 - 36	20 - 45	25 - 50	28 - 60	30 - 70	35 - 80																						
Inside diameter of elastomer (mm)	D _E	6.2	10.2	14.2	19.2	26.2	29.2	36.2	43	46.2	55	60.5																						
Clamping screw (ISO 4762)	E	M2	M3	M4	M5	M6	M8	M10	M12	M12	M12	M16																						
Tightening torque of the clamping screw (Nm)	E	0.6	2	4	8	15	35	70	120	120	120	290																						
Distance between centers (mm)	F	5.5	8	10.5	15.5	21	24	29	33.5	38	47	50.5																						
Distance (mm)	G	3	4	5	8.5	10	11	15	16	17.5	20	23																						
Hub length (mm)	H	12	16.7	20.7	31	36	39	52	55	57	68	74																						
Moment of inertia per hub (10 ⁻³ kgm ²)	J ₁ /J ₂	0.0003	0.002	0.003	0.01	0.04	0.08	0.5	0.8	1.1	2.66	14																						
Approx. weight (kg)		0.008	0.02	0.05	0.12	0.3	0.5	0.9	1.1	1.5	2.5	9																						
Speed standard (min ⁻¹)		15,000	15,000	13,000	12,500	11,000	10,000	9,000	8,500	8,000	6,800	4,000																						
Speed balanced (10 ³ min ⁻¹)		60 67 45 57 65 43 53 63 40 45 60 35 31 31 25 22 26 18 22 26 16 17 18 13 16 17 12 14 14 10 13 13 8																																

For information on shaft misalignment, torsional stiffness, and other details about the elastomer inserts see pages 64.

ELASTOMER COUPLINGS EK | SP

EKH

With split clamping hub

4 – 2,150 Nm



Features

- Lateral mounting
- Easy installation and removal
- Allows for pre-alignment of shafts

Material

- **Hubs:** up to size 600 high strength aluminum; size 800 steel
- **Elastomer:** wear resistant thermally stable TPU

Design

Two concentrically machined, fully split hubs with curved jaws and clamping screws.

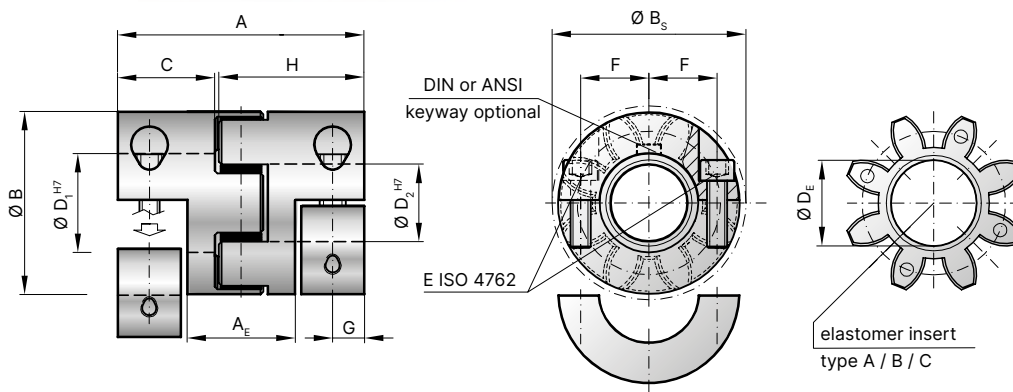

Model EKH

Size		10			20			60			150			300			400			450			600			800		
Type (Elastomer insert)		A	B	C	A	B	C	A	B	C	A	B	C	A	B	C	A	B	C	A	B	C	A	B	C	A	B	C
Rated torque (Nm)	T_{KN}	12.6	16	4	17	21	6	60	75	20	160	200	42	325	405	84	410	520	90	530	660	95	700	840	150	950	1,100	240
Max, torque (Nm)	T_{Kmax}	25	32	6	34	42	12	120	150	35	320	400	85	650	810	170	820	1,040	180	1,060	1,350	190	1,400	1,680	300	1,900	2,150	400
Overall length (mm)	A	53			66			78			90			114			120			126			141			162		
Length of center section (mm)	A_E	20			28.8			34			38			50			52			52			56			65		
Outside diameter (mm)	B	32			42			56			66.5			82			95			102			120			136.5		
Outside diameter with screw head (mm)	B_s	32			44.5			57			68			85			98			105			122			139		
Mounting length (mm)	C	20			25			30			35			45			47			50			55			65		
Inside diameter range H7 (mm)	$D_{1/2}$	6 - 16			8 - 25			12 - 32			19 - 36			20 - 45			25 - 50			28 - 60			30 - 70			35 - 80		
Inside diameter of elastomer (mm)	D_E	14.2			19.2			26.2			29.2			36.2			43			46.2			55			60.5		
Clamping screw (ISO 4762)		4 x M4			4 x M5			4 x M6			4 x M8			4 x M10			4 x M12			4 x M12			4 x M12			4 x M16		
Tightening torque of the clamping screw (Nm)	E	4			8			15			35			70			120			120			120			290		
Distance between centers (mm)	F	10.5			15.5			21			24			29			33.5			38			47			50.5		
Distance (mm)	G/ G_1	7.5			8.5			10			12			15			16			17.5			20			23		
Hub length (mm)	H/ H_1	31			39			46			52.5			66			73			73			83			93.5		
Moment of inertia per hub (10^{-3} kgm^2)	J_1/J_2	0.005			0.02			0.06			0.1			0.55			1.11			1.6			3.45			18.5		
Approx, weight (kg)		0.08			0.15			0.35			0.6			1.2			1.57			2.1			3.22			14.8		
Speed standard (min^{-1})		13,000			12,500			11,000			10,000			9,000			8,500			8,000			6,800			4,000		
Speed balanced (10^3 min^{-1})		53	63	40	45	60	35	31	31	25	22	26	18	22	26	16	17	18	13	16	17	12	14	14	10	13	13	8

For information on shaft misalignment, torsional stiffness, and other details about the elastomer inserts see pages 64.

EK6

With conical clamping ring

4 – 2,150 Nm



Features

- High clamping pressure
- Self centering on shaft
- Very high concentricity

Material

- **Hubs:** up to size 600 high strength aluminum; size 800 steel
- **Elastomer:** wear resistant thermally stable TPU

Design

Two concentrically machined hubs with curved jaws and conical clamping rings.

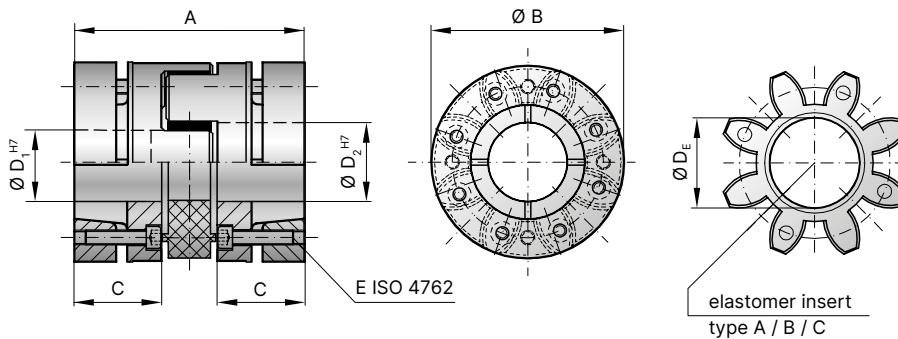

Model EK6

Size		10			20			60			150			300			400			450			600			800		
Type (Elastomer insert)		A	B	C	A	B	C	A	B	C	A	B	C	A	B	C	A	B	C	A	B	C	A	B	C	A	B	C
Rated torque (Nm)	T_{KN}	12.6	16	4	17	21	6	60	75	20	160	200	42	325	405	84	410	520	90	530	660	95	700	840	150	950	1,100	240
Max. torque (Nm)	T_{Kmax}	25	32	6	34	42	12	120	150	35	320	400	85	650	810	170	820	1,040	180	1,060	1,350	190	1,400	1,680	300	1,900	2,150	400
Overall length (mm)	A	42			56			64			76			96			107			110			121			138		
Outside diameter (mm)	B/B ₁	32			43			56			66.5			82			95			102			120			136.5		
Mounting length (mm)	C	15			20			23			28			36			39			42			44.5			53		
Inside diameter range H7 (mm)	D _{1/2}	6 - 16			8 - 24			12 - 32			19 - 35			20 - 45			25 - 50			28 - 55			30 - 70			32 - 80		
Inside diameter of elastomer (mm)	D _E	14.2			19.2			26.2			29.2			36.2			43			46.2			55			60.5		
Clamping screw (ISO 4762)	E	3x M3			6x M4			4x M5			8x M5			8x M6			8x M8			8x M8			8x M8			8x M10		
Tightening torque of the clamping screw (Nm)	E	2			3			6			7			12			20			25			35			55		
Moment of inertia per hub (10 ⁻³ kgm ²)	J ₁ /J ₂	0.004			0.015			0.05			0.1			0.3			0.8			0.85			3			9.2		
Approx. weight (kg)		0.08			0.12			0.3			0.6			1.1			1.5			2.1			2.9			12		
Speed standard (min ⁻¹)		20,000			19,000			14,000			13,000			10,000			9,500			9,000			6,800			4,000		
Speed balanced (10 ³ min ⁻¹)		53	63	40	45	60	35	31	31	25	22	26	18	22	26	16	17	18	13	16	17	12	14	14	10	13	13	8

For information on shaft misalignment, torsional stiffness, and other details about the elastomer inserts see pages 64.

EK6

With conical clamping ring

1,950 – 25,000 Nm



Features

- High clamping pressure
- Self centering on shaft
- Very high concentricity

Material

- **Hubs:** GGG40
- **Elastomer:** wear resistant thermally stable TPU

Design

Two concentrically machined hubs with curved jaws and conical clamping rings. Elastomer insert consist of 5 segments.

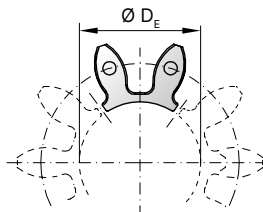
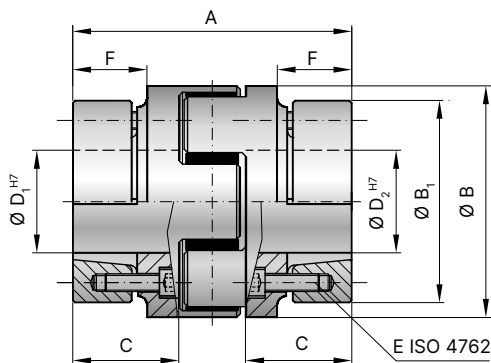

elastomer insert type A / B

Model EK6

Size			2,500		4,500		9,500	
Type (Elastomer insert)			A	B	A	B	A	B
Rated torque	(Nm)	T_{KN}	1,950	2,450	5,000	6,200	10,000	12,500
Max. torque	(Nm)	T_{Kmax}	3,900	4,900	10,000	12,400	20,000	25,000
Overall length	(mm)	A	177		227		282	
Outside diameter	(mm)	B/B ₁	160 / 159		225 / 208		290 / 285	
Mounting length	(mm)	C	70		90		112	
Inside diameter range H7	(mm)	D _{1/2}	40 - 95		50 - 130		60 - 170	
Inside diameter of elastomer	(mm)	D _E	80		111		145	
Clamping screw (ISO 4762)			10x M10		10x M12		10x M16	
Tightening torque of the clamping screw	(Nm)	E	60		100		160	
Distance	(mm)	F	51		66		80	
Moment of inertia per hub	(10 ⁻³ kgm ²)	J ₁ /J ₂	31.7		135.7		469.2	
Approx. weight	(kg)		19.5		35		73	
Speed standard	(min ⁻¹)		3,500		3,000		2,000	
Speed balanced	(10 ³ min ⁻¹)		10	10	8	8	6.5	6.5

For information on shaft misalignment, torsional stiffness, and other details about the elastomer inserts see pages 64.

SP6

High speed with conical clamping ring

60 – 2,150 Nm

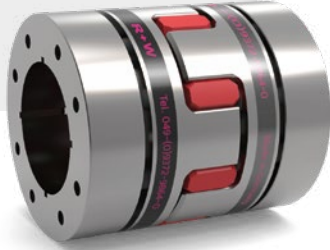

Features

- Very high precision
- Very high concentricity
- High clamping force
- Symmetrically machined hubs

Material

- **Hubs:** high strength aluminium; optional steel
- **Clamping ring:** high strength aluminium; optional steel
- **Elastomer:** wear resistant thermally stable TPU

Design

Two precision machined hubs with curved jaws and conical clamping rings.

Fit clearance

Overall shaft / hub tolerance 0.01 - 0.025 mm

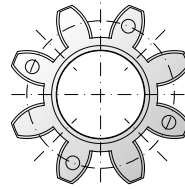
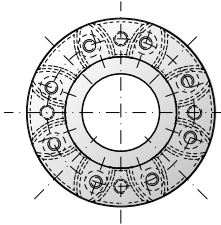
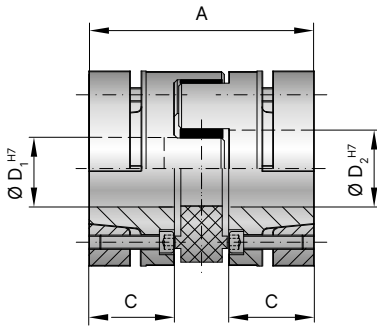

High speed

Model SP6

Size	60		150		300		400		450		600		800	
Type (Elastomer insert)	A	B	A	B	A	B	A	B	A	B	A	B	A	B
Rated torque (Nm) T_{KN}	60	75	160	200	325	405	410	520	530	660	700	840	950	1,100
Max. torque* (Nm) T_{Kmax}	120	150	320	400	650	810	820	1,040	1,060	1,350	1,400	1,680	1,900	2,150
Overall length (mm)	A	64	78	80	90	100	114	126	110	126	140	160	138	
Outside diameter(mm)	B	55		65			80	95		102		120	136.5	
Mounting length (mm)	C	23	30	30	35	40	45	50	42	50	57	65	53	
Inside diameter range H7 (mm)	$D_{1/2}^*$	14 - 32		19 - 38			20 - 48**	25 - 50		28 - 55		35 - 70	40 - 80	
Inside diameter of elastomer (mm)	D_E	26.2		29.2			36.2	43		46.2		55	60.5	
Hub material)														steel
Clamping screw (ISO 4762)		4x M5		8x M5			8x M6	8x M8		8x M8		8x M8	8x M10	
Tightening torque of the clamping screw - AL / steel(Nm)	E	6 / 6	7 / 7	7 / 8.5	7.5 / 8.5	8.5 / 8.5	14 / 14	23 / 30		25 / 30		30 / 35	46 / 63	
Moment of inertia per hub AL / steel (10^{-3} kgm^2)	J_1/J_2	0.06 / 0.15	0.08 / 0.20	0.16 / 0.38	0.18 / 0.44	0.20 / 0.50	0.52 / 1.29	1.25 / 3.05	1.33 / 3.31	1.55 / 3.88	1.74 / 4.38	3.80 / 9.60	5.52 / 13.72	
Approx. weight AL / steel (kg)		0.25 / 0.62	0.32 / 0.78	0.46 / 1.10	0.53 / 1.30	0.60 / 1.43	1.00 / 2.41	1.76 / 4.17	1.70 / 4.00	1.90 / 4.70	2.20 / 5.20	3.22 / 8.00	3.73 / 9.17	
Speed standard (min-1)		28,000		26,000			26,000	19,000		18,000		15,000	13,500	

For information on shaft misalignment, torsional stiffness, and other details about the elastomer inserts see pages 64.

* Recommended fit pairing H7 / k6; H6 / j5 (short spindle); starting at Ø55 G7 / m6

** from Ø46 to 48 with custom hub

EK7

With expanding shaft

2 – 2,150 Nm



Features

- For hollow shaft mounting
- Short overall length
- Solution for mismatched bore / shaft diameters

Material

- **Hubs:** up to size 600 high strength aluminum; size 800 steel
- **Expanding shaft hub:** steel
- **Elastomer:** wear resistant thermally stable TPU

Design

One concentrically machined hub with clamping screw and curved jaws. One concentrically machined hub with expanding shaft system and curved jaws.

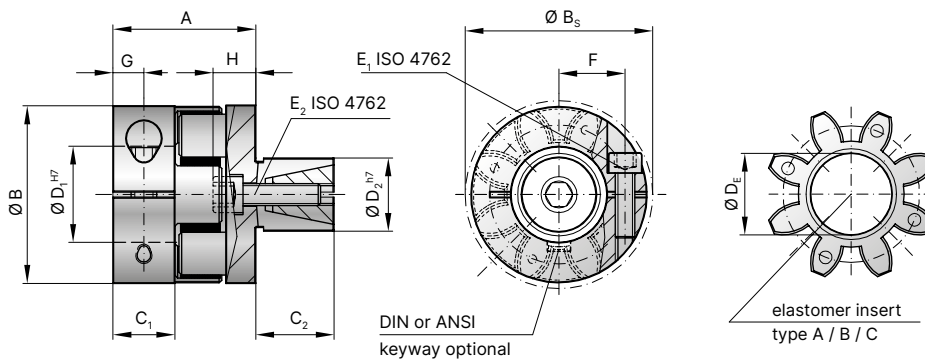

Model EK7

Size		5			10			20			60			150			300			400			450			600			800		
Type (Elastomer insert)		A	B	C	A	B	C	A	B	C	A	B	C	A	B	C	A	B	C	A	B	C	A	B	C	A	B	C	A	B	C
Rated torque (Nm)	T_{KN}	9	12	2	12.5	16	4	17	21	6	60	75	20	160	200	42	325	405	84	410	520	90	530	660	95	700	840	150	950	1,100	240
Max. torque (Nm)	T_{Kmax}	18	24	4	25	32	6	34	42	12	120	150	35	320	400	85	650	810	170	820	1,040	180	1,060	1,350	190	1,400	1,680	300	1,900	2,150	400
Overall length (mm)	A	22.3			28			40			46			51			68			74			76			88			94		
Outside diameter (mm)	B	25			32			42			56			66.5			82			95			102			120			136.5		
Outside diameter with screw head (mm)	B_s	25			32			44.5			57			68			85			98			105			122			139		
Mounting length (mm)	C_1	8			10.3			17			20			21			31			32			34			40			46		
Mounting length (mm)	C_2	12			20			25			27			32			45			50			55			55			60		
Inside diameter range H7 (mm)	D_1	4 - 12.7			5 - 16			8 - 25			12 - 32			19 - 36			20 - 45			25 - 50			28 - 60			30 - 70			35 - 80		
Outside diameter range h7 (mm)	D_2	10 - 16			13 - 25			14 - 30			23 - 38			26 - 45			38 - 60			40 - 65			42 - 70			42 - 75			42 - 80		
Inside diameter of elastomer (mm)	D_E	10.2			14.2			19.2			26.2			29.2			36.2			43			46.2			55			60.5		
Clamping screw (ISO 4762)	E_1	M3			M4			M5			M6			M8			M10			M12			M12			M12			M16		
Tightening torque (Nm)		2			4			8			15			35			70			120			120			120			290		
Clamping screw (ISO 4762)	E_2	M4			M5			M6			M8			M10			M12			M16			M16			M16			M16		
Tightening torque (Nm)		4			9			12			32			60			110			240			240			240			300		
Distance between centers (mm)	F	8			10.5			15.5			21			24			29			33.5			38			47			50.5		
Distance (mm)	G	4			5			8.5			10			11			15			16			17.5			20			23		
Length (mm)	H	7			7			10			11			16			20			27			27			27			27		
Moment of inertia D_1 (10^{-3} kgm ²)	J_1	0.002			0.003			0.01			0.04			0.08			0.5			0.82			1.1			2.66			14		
Moment of inertia D_2 (10^{-3} kgm ²)	J_2	0.002			0.01			0.04			0.1			0.2			1			1.92			2.6			4.97			9		
Approx. weight (kg)		0.04			0.05			0.12			0.3			0.5			0.9			2.82			3.5			4.88			7.6		
Speed standard (min ⁻¹)		15,000			13,000			12,500			11,000			10,000			9,000			8,500			8,000			6,800			4,000		
Speed balanced (10^3 min ⁻¹)		57	65	43	53	63	40	45	60	35	31	31	25	22	26	18	22	26	16	17	18	13	16	17	12	14	14	10	13	13	8

For information on shaft misalignment, torsional stiffness, and other details about the elastomer inserts see pages 64.



Intermediate spacer



Features

- High lateral misalignment
- Easy to mount
- Combine with any two hub designs

Material

- **Hubs:** high strength aluminum
- **Elastomer:** wear resistant thermally stable TPU

Design

A concentrically machined spacer with curved jaws. 2x elastomer segment press fit for zero backlash; standard versions are electrically isolating.

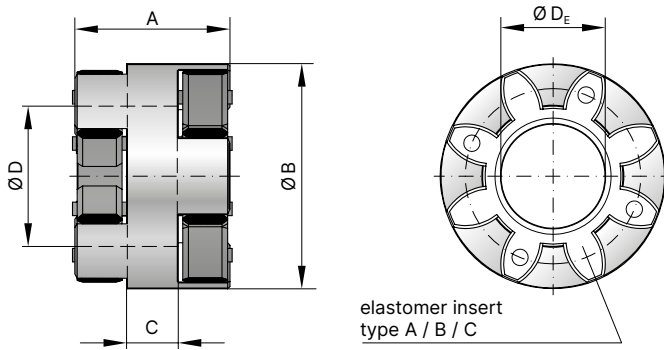

Model EKZ

Size		2			5			10			20			60			150			300			400			450			600			800		
Type (Elastomer insert)		A	B	C	A	B	C	A	B	C	A	B	C	A	B	C	A	B	C	A	B	C	A	B	C	A	B	C	A	B	C	A	B	C
Rated torque (Nm)	T_{KN}	2	2.4	0.5	9	12	2	12.5	16	4	17	21	6	60	75	20	160	200	42	325	405	84	410	520	90	530	660	95	700	840	150	950	1,100	240
Max, torque (Nm)	T_{Kmax}	4	4.8	1	18	24	4	25	32	6	34	42	12	120	150	35	320	400	85	650	810	170	820	1,040	180	1,060	1,350	190	1,400	1,680	300	1,900	2,150	400
Overall length (mm)	A	20			26			30			39			48			53			62			74			86			86			81		
Outside diameter (mm)	B	16			25			32			42			56			66.5			82			94			102			119			136.5		
Hub length (mm)	C	9			9			9			10			16			18			20			28			40			30			25		
Inside diameter (mm)	D	9			15			18			25			32			38			45			50			60			65			80		
Inside diameter of elastomer (mm)	D_E	6.2			10.2			14.2			19.2			26.2			29.2			36.2			43			46.2			55			60.5		
Moment of inertia (10^{-3} kgm^2)	J_1/J_2	0.0001			0.0005			0.002			0.008			0.03			0.05			0.1			0.47			0.6			1.39			1.1		
Approx, weight (kg)		0.007			0.02			0.04			0.09			0.21			0.33			0.58			0.675			1.38			1.24			1.24		
Speed standard (min^{-1})		15,000			15,000			13,000			12,500			11,000			10,000			9,000			8,500			8,000			6,800			4,000		

For information on shaft misalignment, torsional stiffness, and other details about the elastomer inserts see pages 64.



SK

SL

ES

Backlash free torque limiters

0.1 – 2,800 Nm

Areas of application

for overload protection in:

- + Machine tools
- + Packaging machinery
- + Metal forming equipment
- + Test stands
- + Pump drives
- + Assembly systems
- + For overload protection

Service life

As long as the technical limits are not exceeded these couplings are wear and maintenance free.

Fit clearance

Overall shaft / hub clearance of 0.01 - 0.05 mm

Special solutions

Various materials, tolerances, dimensions and performance ratings available for custom applications on request.

ATEX (Optional)

Available on request.

Ordering Example	SK2	15	75	D	10	14	8	7-15	XX
Model	•								Special designation only (e.g. special bore / keyway dimensions).
Size		•							
Overall length mm			•						
Function system				•					
Bore D1 H7					•				
Bore D2 H7						•			
Disengagement torque Nm							•		
Torque adjustment range Nm								•	

For custom features place an XX at the end of the part number and describe the special requirements (e.g. SK2 / 15 / 75 / D / 10 / 14 / 8 / 7-15 / XX)





SK



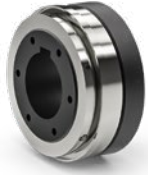

SL

ES

Backlash free torque limiters

0.1 – 2,800 Nm

Model		Features	Page
SK1		<p>With conical clamping bushing (or clamping hub in smaller sizes) for indirect drives 0.1 – 2,800 Nm</p> <ul style="list-style-type: none"> • Integral bearing to support sprockets, gears, and other drive elements • Compact simple design • Adjustable torque settings 	84-85
SKP		<p>With keyway connection for indirect drives 0.1 – 2,800 Nm</p> <ul style="list-style-type: none"> • Integral bearing to support sprockets, gears, and other drive elements • Compact simple design • Adjustable torque settings 	86
SLP		<p>With keyway connection for indirect drives 10 - 700 Nm</p> <ul style="list-style-type: none"> • Integral bearing to support sprockets, gears, and other drive elements • Adjustable torque settings • Ultra compact, low inertia version 	87
SKN		<p>With clamping hub for indirect drives 5 – 1,800 Nm</p> <ul style="list-style-type: none"> • Integral bearing to support sprockets, gears, and other drive elements • Compact simple design • Adjustable torque settings 	88
SLN		<p>With clamping hub for indirect drives 10 - 700 Nm</p> <ul style="list-style-type: none"> • Integral bearing to support sprockets, gears, and other drive elements • Adjustable torque settings • Ultra compact, low inertia version 	89

Model	Features	Page
 <p data-bbox="148 667 199 696">SK2</p>	<p data-bbox="592 645 1305 712">With clamping hubs and bellows coupling for direct drives 0.1 – 1,800 Nm</p> <ul data-bbox="592 734 1062 837" style="list-style-type: none"> <li data-bbox="592 734 783 763">• Easy to mount <li data-bbox="592 770 1062 799">• Compensation for shaft misalignment <li data-bbox="592 806 927 837">• Adjustable torque settings 	90
 <p data-bbox="148 969 199 999">SL2</p>	<p data-bbox="592 947 1305 1014">With clamping hubs and bellows coupling for direct drives 10 – 400 Nm</p> <ul data-bbox="592 1037 1062 1178" style="list-style-type: none"> <li data-bbox="592 1037 783 1066">• Easy to mount <li data-bbox="592 1072 1062 1102">• Compensation for shaft misalignment <li data-bbox="592 1108 927 1137">• Adjustable torque settings <li data-bbox="592 1144 1015 1178">• Ultra compact, low inertia version 	91
 <p data-bbox="148 1267 199 1296">SKH</p>	<p data-bbox="592 1245 1082 1312">With split clamping hub for direct drives 0.1 – 2,800 Nm</p> <ul data-bbox="592 1335 1305 1438" style="list-style-type: none"> <li data-bbox="592 1335 911 1364">• Radial mounting possible <li data-bbox="592 1370 1015 1400">• Very easy to mount and dismount <li data-bbox="592 1406 1305 1438">• Torque limiter element: spring loaded ball-detent principle 	
 <p data-bbox="148 1570 199 1599">SK3</p>	<p data-bbox="592 1547 1249 1615">With conical clamping bushings and bellows coupling for direct drives 5 – 2,800 Nm</p> <ul data-bbox="592 1673 1062 1778" style="list-style-type: none"> <li data-bbox="592 1673 895 1702">• High clamping pressure <li data-bbox="592 1709 1062 1738">• Compensation for shaft misalignment <li data-bbox="592 1744 927 1778">• Adjustable torque settings 	94
 <p data-bbox="148 1868 199 1897">SK5</p>	<p data-bbox="592 1845 1350 1912">With clamping hubs, bellows coupling, and blind mate system for direct drives 0,1 – 850 Nm</p> <ul data-bbox="592 1973 1018 2074" style="list-style-type: none"> <li data-bbox="592 1973 1018 2002">• Very easy to mount and dismount <li data-bbox="592 2009 1018 2038">• Electrically and thermally isolating <li data-bbox="592 2045 927 2074">• Adjustable torque settings 	95



SK

SL

ES

Backlash free torque limiters

0.1 – 2,800 Nm

Model		Features	Page
ES2		<p>With clamping hubs and elastomer coupling for direct drives 1 – 1,800 Nm</p> <ul style="list-style-type: none"> • Easy to mount • Vibration damping • Compensation for shaft misalignment • Adjustable torque settings 	96
SLE		<p>With clamping hubs and elastomer coupling for direct drives 10 - 700 Nm</p> <ul style="list-style-type: none"> • Easy to mount • Vibration damping • Compensation for shaft misalignment • Adjustable torque settings • Ultra compact, low inertia version 	97
ESL		<p>With keyway mounting and elastomer coupling for direct drives 1 – 150 Nm</p> <ul style="list-style-type: none"> • Low cost design • Vibration damping • Wear resistant ratcheting ball design 	98
Accessories			99-100

SK1

With conical clamp

0.1 – 2,800 Nm



Features

- Integral bearing to support sprockets, gears, and other drive elements
- Compact simple design
- Adjustable torque settings

Material

- **Torque limiter element:** hardened steel
- **Clamping ring size 1.5 - 10:** aluminium
- **Conical clamping bushing size 15 - 2,500:** steel

Design

Size 1.5 - 10 with clamping ring and a single clamping screw.
 Size 15 - 2,500 with conical clamping bushing and six screws.
 Torque limiter system: spring loaded ball-detent principle.
 Operable temperature range from -30°C to +120°C.

Available function systems

- W = Single position / automatic re-engagement (standard)
- D = Multi-position / automatic re-engagement
- G = Load holding / load blocking
- F = Full disengagement / manual re-engagement

Miniature design Size 1.5 - 10

Standard with
clamping collar

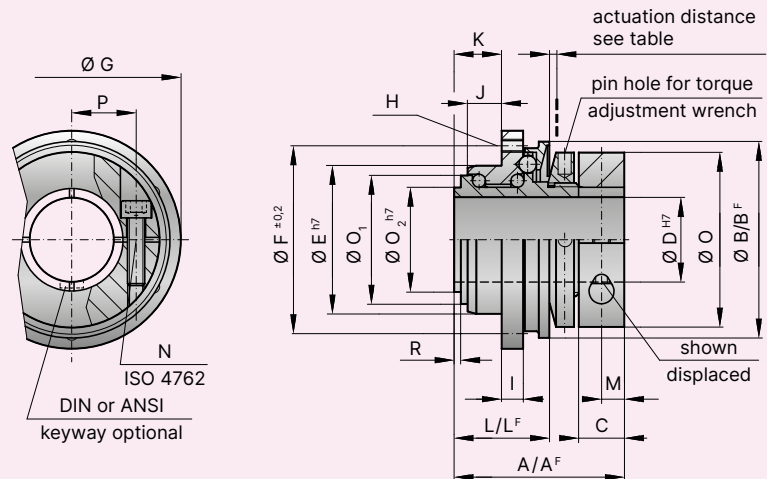

Standard design Size 15 - 2,500

Standard with
conical clamping bushing

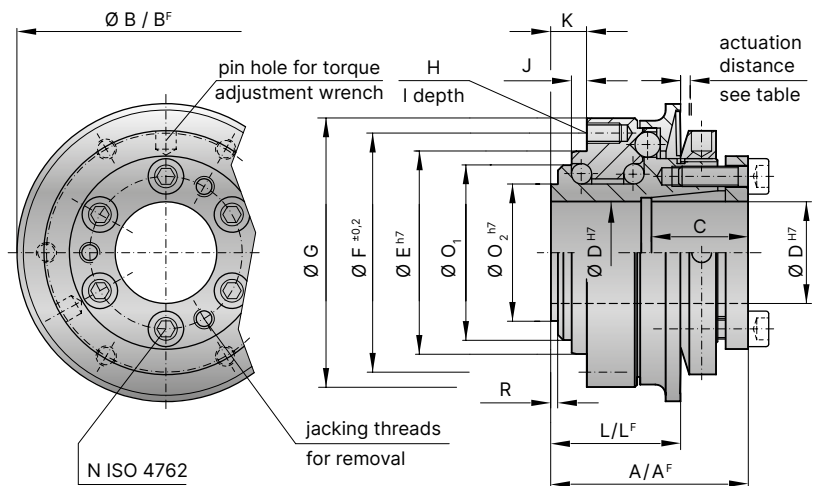

Model SK1

		Miniature design													
Size		1.5	2	4.5	10	15	30	60	150	200	300	500	800	1,500	2,500
Adjustment range available from - to (Nm) (approx. values)	T _{KN}	0.1-0.6 0.4-1 0.8-2	0.2-1.5 0.5-2.2 1.5-3.5	1-3 2-4.5 3-7	2-6 4-12 7-18	5-15 12-25 20-40 35-70	5-20 10-30 20-60 50-100	10-30 25-80 50-115	20-70 45-150 80-225	30-90 60-160 140-280 250-400	100-200 150-240 220-440	80-200 200-350 320-650	400-650 500-800 650-950	600-800 700-1,200 1,000-1,800	1,500-2,000 2,000-2,500 2,300-2,800
Adjustment range from - to (Nm) (approx. values) ("F" Version)	T _{KN}	0.3-0.8 or 0.6-1.3	0.2-1 or 0.7-2	2.5-4.5	2-5 4-10 8-15	7-15	8-20 or 16-30	10-30 20-40 30-60	20-60 40-80 80-150	80-140 oder 130-200	120-180 160-300 300-450	50-150 100-300 250-500	200-400 or 450-850	1,000-1,250 or 1,250-1,500	1,400-2,200 or 1,800-2,700
Overall length (mm)	A	23	28	32	39	40	50	54	58	63	70	84	95	109	146
Overall length ("F" Version) (mm)	A ^F	23	28	32	39	40	50	54	58	66	73	88	95	117	152
Actuation ring Ø (mm)	B	23	29	35	45	55	65	73	92	99	120	135	152	174	242
Actuation ring Ø, ("F" Version) (mm)	B ^F	24	32	42	51.5	62	70	83	98	117	132	155	177	187	258
Clamping fit length (mm)	C	7	8	11	11	19	22	27.5	32	32	41	41	49	61	80
Inner diameter from Ø to Ø H7 (mm)	D	4-8	4-12	5-14	6-20	8-22	12-22	12-29	15-37	20-44	25-56	25-56	30-60	35-70	50-100
Pilot diameter h7 (mm)	E	14	22	25	34	40	47	55	68	75	82	90	100	125	168
Bolt-hole circle diameter ± 0.2 (mm)	F	22	28	35	43	47	54	63	78	85	98	110	120	148	202
Flange outside diameter -0.2 (mm)	G	26	32	40	50	53	63	72	87	98	112	128	140	165	240
Thread	H	4xM2	4xM2.5	6xM2.5	6xM3	6xM4	6xM5	6xM5	6xM6	6xM6	6xM8	6xM8	6xM10	6xM12	6xM16
Thread depth (mm)	I	3	4	4	5	6	8	9	10	10	10	12	15	16	24
Centering length -0.2 (mm)	J	2.5	3.5	5	8	3	5	5	5	5	6	9	10	13.5	20
Distance (mm)	K	5	6	8	11	8	11	11	12	12	15	21	19	25	34
Distance (mm)	L	11	15	17	22	27	35	37	39	44	47	59	67	82	112
Distance, ("F" Version) (mm)	L ^F	11.5	16	18	24	27	37	39	41.5	47	51.5	68	75	94	120
Distance (mm)	M	3.5	4	5	5										
Screw ISO 4762	N	1xM2.5	1xM3	1xM4	1xM4	6xM4	6xM5	6xM5	6xM6	6xM6	6xM8	6xM8	6xM10	6xM12	6xM16
Tightening torque (Nm)		1	2	4	4.5	4	6	8	12	14	18	25	40	70	120
Outside diameter clamp ring Ø (mm)	O	20	25	32	40										
Diameter (mm)	O ₁	13	18	21	30	35	42	49	62	67	75	84	91	112	154
Diameter h7 (mm)	O ₂	11	14	17	24	27	32	39	50	55	65	72	75	92	128
Distance between centers (mm)	P	6.5	8	10	15										
Distance (mm)	R	1	1.3	1.5	1.5	2.5	2.5	2.5	2.5	3	3	4	4	4.5	6
Moment of inertia (10 ⁻³ kgm ²)	J _{ges}	0.01	0.02	0.05	0.07	0.15	0.25	0.50	1.60	2.70	5.20	8.6	20	31.5	210
Approx. weight (kg)		0.03	0.065	0.12	0.22	0.4	0.7	1.0	1.3	2.0	3.0	4.0	5.5	10	28
Actuation distance (mm)		0.7	0.8	0.8	1.2	1.5	1.5	1.7	1.9	2.2	2.2	2.2	2.2	3.0	3.0

A^F, B^F, L^F = Full disengagement / manual re-engagement version (F)

SKP

With keyway connection

0.1 – 2,800 Nm

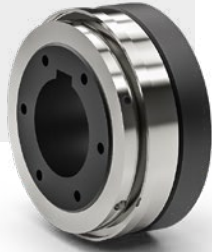

Features

- Integral bearing to support sprockets, gears, and other drive elements
- Compact simple design
- Adjustable torque settings

Material

- **Torque limiter element:** hardened steel

Design

With DIN 6885 or ANSI B17.1 keyway. Torque limiter system: spring

loaded ball-detent principle.

Operable temperature range from -30°C to +120°C.

Available function systems

- W = Single position / automatic re-engagement (standard)
- D = Multi-position / automatic re-engagement
- G = Load holding / load blocking
- F = Full disengagement / manual re-engagement

Miniature design Size 1.5 - 10

Standard with keyway mounting

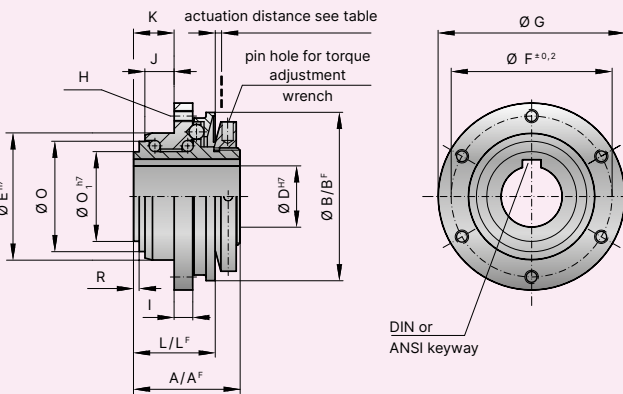

Standard design Size 15 - 2,500

Standard with keyway mounting

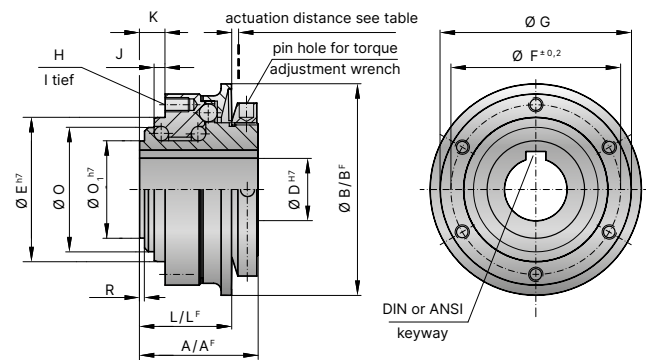

Model SKP

Miniature design

Size		1.5	2	4.5	10	15	30	60	150	200	300	500	800	1,500	2,500
Adjustment range available from - to (approx. values)	(Nm) T_{KN}	0.1-0.6 0.4-1 0.8-2	0.2-1.5 0.5-2.2 1.5-3.5	1-3 2-4.5 3-7	2-6 4-12 7-18	5-15 12-25 20-40 35-70	5-20 10-30 20-60 50-100	10-30 25-80 20-40 50-115	20-70 45-150 40-80 80-225	30-90 60-160 140-280 250-400	100-200 150-240 220-440	80-200 200-350 320-650	400-650 500-800 650-950	600-800 700-1,200 1,000-1,800	1,500-2,000 2,000-2,500 2,300-2,800
Adjustment range available from - to (approx. values) ("F" Version)	(Nm) T_{KN}	0.3-0.8 or 0.6-1.3	0.2-1 or 0.7-2	2.5-4.5	2-5 4-10 8-15	7-15	8-20 or 16-30	10-30 20-40 30-60	20-60 40-80 80-150	80-140 oder 160-300 130-200	120-180 100-300 300-450	50-150 or 100-300 250-400	200-400 or 450-850	1,000-1,250 or 1,250-1,500	1,400-2,200 or 1,800-2,700
Overall length A	(mm) A	15.5	20	22	28	34	43	46	48.5	54	57	71.5	80	99	135
Overall length ("F" Version)	(mm) A ^F	15.5	20	22	28	34	43	46	48.5	57	60	75	91	110	141
Actuation ring Ø	(mm) B	23	29	35	45	55	65	73	92	99	120	135	152	174	242
Actuation ring Ø, ("F" Version)	(mm) B ^F	24	32	42	51.5	62	70	83	98	117	132	155	177	187	258
Inner diameter from Ø to Ø H7	(mm) D	4-8*	4-10*	4-12*	4-16*	8-18	12-25.4	12-28	15-38	20-42	25-50	25-58	30-60	35-73	50-98
Inner diameter with keyway DIN 6885-3 (flat)	(mm) D	-	-	-	16-18	18-20	25.4-27	28-30	38-40	42-44	50-52	58-60	60-63	73-75	98-100
Pilot diameter h7	(mm) E	14	22	25	34	40	47	55	68	75	82	90	100	125	168
Bolt-hole circle diameter ± 0.2	(mm) F	22	28	35	43	47	54	63	78	85	98	110	120	148	202
Flange outside diameter -0.2 (mm)	G	26	32	40	50	53	63	72	87	98	112	128	140	165	240
Thread	H	4xM2	4xM2.5	6xM2.5	6xM3	6xM4	6xM5	6xM5	6xM6	6xM6	6xM8	6xM8	6xM10	6xM12	6xM16
Thread depth	(mm) I	3	4	4	5	6	8	9	10	10	10	12	15	16	24
Centering length -0.2	(mm) J	2.5	3.5	5	8	3	5	5	5	5	6	9	10	13.5	20
Distance	(mm) K	5	6	8	11	8	11	11	12	12	15	21	19	25	34
Distance	(mm) L	11	15	17	22	27	35	37	39	44	47	59	67	82	112
Distance, ("F" Version)	(mm) L ^F	11.5	16	18	24	27	37	39	41.5	47	51.5	68	75	94	120
Diameter	(mm) O	13	18	21	30	35	42	49	62	67	75	84	91	112	154
Diameter h7	(mm) O ₁	11	14	17	24	27	32	39	50	55	65	72	75	92	128
Distance	(mm) R	1	1.3	1.5	1.5	2.5	2.5	2.5	2.5	3	3	4	4	4.5	6
Moment of inertia (10 ⁻³ kgm ²)	J _{ges}	0.01	0.02	0.05	0.07	0.15	0.25	0.50	1.60	2.70	5.20	8.6	20	31.5	210
Approx. weight	(kg)	0.03	0.065	0.12	0.22	0.4	0.7	1.0	1.3	2.0	3.0	4.0	5.5	10	28
Actuation distance	(mm)	0.7	0.8	0.8	1.2	1.5	1.5	1.7	1.9	2.2	2.2	2.2	2.2	3.0	3.0

A^F, B^F, L^F = Full disengagement / manual re-engagement version (F)

* bore diameter < 6 mm delivered without keyway

SLP

With keyway connection

10 – 700 Nm



Features

- Integral bearing to support sprockets, gears, and other drive elements
- Adjustable torque settings
- Ultra compact, low inertia version

Design

With DIN 6885 or ANSI B17.1 keyway.
Torque limiter system: spring loaded ball-detent principle.
Operable temperature range from -30°C to +120°C.

Available function systems

- W = Single position / automatic re-engagement (standard)
- D = Multi-position / automatic re-engagement

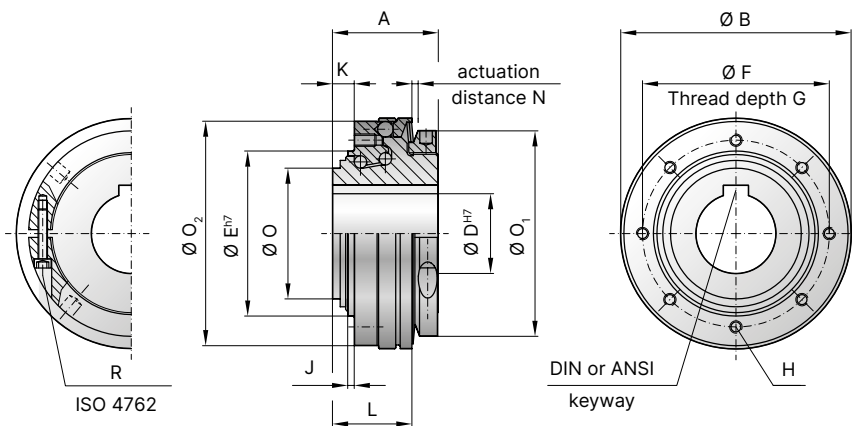

Light weight
safety coupling

Modell SLP

Size			30	60	150	300
Adjustment range* from - to	(Nm)	T_{KN}	10-35 30-80 40-135	30-80 60-120 100-200	40-100 100-200 150-300	200-350 300-450 400-550 550-700
Overall length	(mm)	A	30	35	41	48
Actuation ring diameter	(mm)	B	63	74	92	118
Inner diameter from Ø to Ø H7	(mm)	D	12-25.4 (28)*	16-30 (32)*	19-44 (46)*	22-54 (58)*
Pilot diameter h7	(mm)	E	43	53	68	85
Bolt-hole circle diameter ± 0.2	(mm)	F	48	60	75	95
Thread depth +1	(mm)	G	5	6	7	9
Fastening threads		H	8x M4	8x M4	8x M5	8x M6
Centering length -0.2	(mm)	J	2	2	3	3
Distance	(mm)	K	6	7	9	9
Distance to actuation ring edge	(mm)	L	23	26	32	36
Actuation distance	(mm)	N	1.3	1.5	1.8	2
Ø Base element	(mm)	O	35	42	54	70
Ø Adjustment nut	(mm)	O ₁	55	66	82	100
Ø Flange -0.2	(mm)	O ₂	58	72	87	110
Adjustment nut's clamp screw ISO 4762		R	M3	M3	M3	M4
Tightening torque	(Nm)		2	2	2	4.5
Approx. weight	(kg)		0.2	0.35	0.7	1.1
Approx. moment of inertia at D max.	(10 ⁻³ kgm ²)	J _{ges}	0.1	0.4	1.1	2.3

* maximum bore diameters shown are only available with shallow keyway according to DIN 6885/3 or special heights for inch bores

SKN

With clamping hub

5 – 1,800 Nm



Features

- Integral bearing to support sprockets, gears, and other drive elements
- Compact simple design
- Adjustable torque settings

Material

- **Torque limiter element:** hardened steel
- **Clamping collar:** up to size 500 aluminum, size 800 and up steel

Design

With clamping ring and one clamping screw. Torque limiter system: spring loaded ball-detent principle. Operable temperature range from -30°C to +120°C.

Available function systems

- W = Single position / automatic re-engagement (standard)
- D = Multi-position / automatic re-engagement
- G = Load holding / load blocking
- F = Full disengagement / manual re-engagement

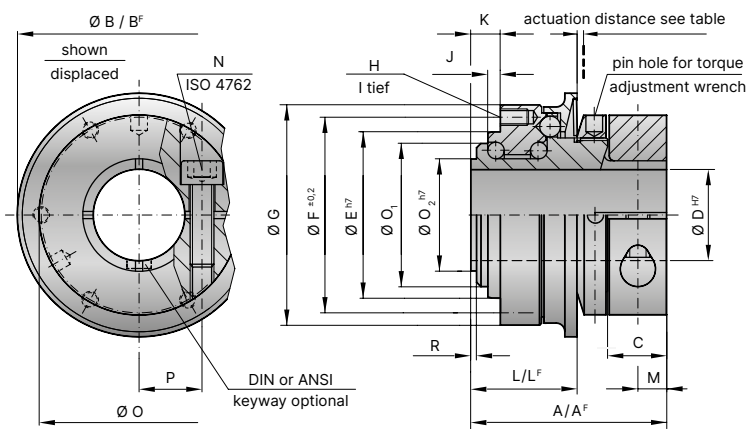

Model SKN

Size			15	30	60	150	200	300	500	800	1,500
Adjustment range available from - to (approx. values)	(Nm)	T _{KN}	5-10 oder 8-20	10-25 oder 20-40	10-30 oder 25-80	20-70 oder 45-150 oder 80-180	30-90 oder 60-160 oder 120-240	100-200 oder 150-240 oder 200-320	80-200 oder 200-350 oder 300-500	400-650 oder 500-800 oder 600-850	600-800 oder 700-1,200 oder 1,000-1,800
Adjustment range available from - to (approx. values) ("F" Version)	(Nm)	T _{KN}	7-15	8-20 oder 16-30	10-30 oder 20-40 oder 30-60	20-60 oder 40-80 oder 80-150	80-140 oder 130-200	120-180 oder 160-300	50-150 oder 100-300 oder 250-500	200-400 oder 600-850 oder 450-800	1,000-1,250 oder 1,250-1,500
Overall length	(mm)	A	47	59	65	71	80	84	101	115	145
Overall length ("F" Version)	(mm)	A ^F	47	59	65	73	83	87	107	126	160
Actuation ring Ø	(mm)	B	55	65	73	92	99	120	135	152	174
Actuation ring Ø, ("F" Version)	(mm)	B ^F	62	70	83	98	117	132	155	177	187
Clamping fit length	(mm)	C	13.5	16	20	23	26	26	30	35	46
Inner diameter from Ø to Ø H7	(mm)	D	12-22*	14-25.4*	16-32	19-40*	24-44	30-56*	35-60*	40-62*	50-72*
Pilot diameter h7	(mm)	E	40	47	55	68	75	82	90	100	125
Bolt-hole circle diameter ± 0.2	(mm)	F	47	54	63	78	85	98	110	120	148
Flange outside diameter -0.2	(mm)	G	53	63	72	87	98	112	128	140	165
Thread		H	6xM4	6xM5	6xM5	6xM6	6xM6	6xM8	6xM8	6xM10	6xM12
Thread depth	(mm)	I	6	8	9	10	10	10	12	15	16
Centering length -0.2	(mm)	J	3	5	5	5	5	6	9	10	13.5
Distance	(mm)	K	8	11	11	12	12	15	21	19	25
Distance	(mm)	L	27	35	37	39	44	47	59	67	82
Distance, ("F" Version)	(mm)	L ^F	27	37	39	41.5	47	51.5	68	75	94
Distance		M	6.5	7.5	9.5	11	13	13	14.5	18	22.5
Screw ISO 4762		N	M5	M6	M8	M10	M12	M12	M14	M16	M20
Tightening torque			8	15	40	70	70	130	210	270	500
Clamp ring Ø		O	49	55	67	85	94	110	121	134	157
Diameter	(mm)	O ₁	35	42	49	62	67	75	84	91	112
Diameter h7	(mm)	O ₂	27	36	39	50	55	65	72	75	92
Distance between centers	(mm)	P	17.5	19	23.5	30	32.5	39	43.5	45	52
Distance	(mm)	R	2.5	2.5	2.5	2.5	3	3	4	4	4.5
Moment of inertia	(10 ⁻³ kgm ²)	J _{ges}	0.15	0.25	0.50	1.60	2.70	5.20	8.60	20	31.5
Approx. weight	(kg)		0.4	0.7	1.0	1.3	2.0	3.0	4.0	5.5	10
Actuation distance	(mm)		1.5	1.5	1.7	1.9	2.2	2.2	2.2	2.2	3.0

A^F, B^F, L^F = Full disengagement / manual re-engagement version (F) * keyway with max. bore only in clamping hub possible.

SLN

With clamping collar

10 – 700 Nm



Features

- Integral bearing to support sprockets, gears, and other drive elements
- Adjustable torque settings
- Ultra compact, low inertia version

Design

With clamping collar and a single clamping screw.
Torque limiter system: spring loaded ball-detent principle.
Operable temperature range from -30°C to +120°C.

Available function systems

- W = Single position / automatic re-engagement (standard)
- D = Multi-position / automatic re-engagement

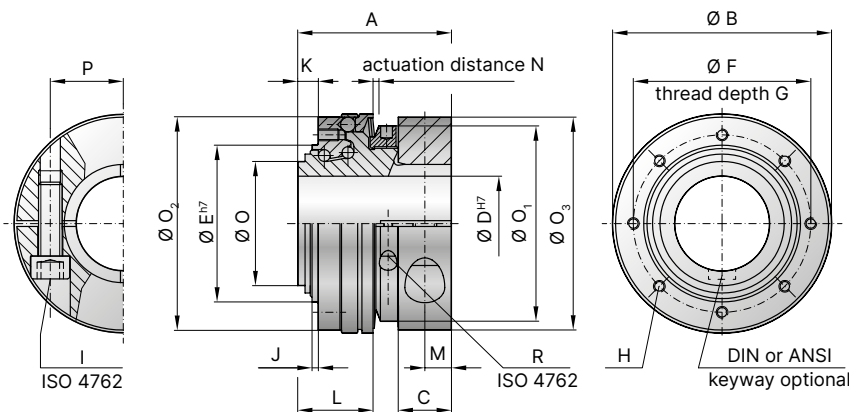

Light weight
safety coupling

Model SLN

Size			30	60	150	300
Adjustment range from - to	(Nm)	T_{KN}	10-35 30-80 40-135	30-80 60-120 100-200	40-100 100-200 150-300	200-350 400-550 300-450 550-700
Overall length	(mm)	A	45	53	63	72
Actuation ring Ø	(mm)	B	63	74	92	118
Clamping fit length	(mm)	C	15	18	22	24
Inner diameter from Ø to Ø H7	(mm)	D	12-30	16-35	19-42	22-60
Pilot diameter h7	(mm)	E	43	53	68	85
Bolt-hole circle diameter ± 0.2	(mm)	F	48	60	75	95
Thread depth +1	(mm)	G	5	6	7	9
Fastening threads		H	8x M4	8x M4	8x M5	8x M6
Screw ISO 4762		I	M6	M8	M10	M12
Tightening torque	(Nm)		15	40	75	130
Centering length -0.2	(mm)	J	2	2	3	3
Distance	(mm)	K	6	7	9	9
Distance to actuation ring edge	(mm)	L	23	26	32	36
Distance	(mm)	M	7.5	9	11	12
Actuation distance	(mm)	N	1.3	1.5	1.8	2
Ø Base element	(mm)	O	35	42	54	70
Ø Adjustment nut	(mm)	O ₁	55	66	82	100
Ø Flange -0.2	(mm)	O ₂	58	72	87	110
Ø Clamp ring	(mm)	O ₃	59	72	90	114
Distance between centers	(mm)	P	21.5	25	33	41
Adjustment nut's clamp screw ISO 4762		R	M3	M3	M3	M4
Tightening torque	(Nm)		2	2	2	4.5
Approx. weight	(kg)		0.3	0.5	0.8	1.5
Approx. moment of inertia at D max	(10 ⁻³ Kgm ²)	J_{ges}	0.15	0.3	1	3

SK2

With clamping hubs

0.1 – 1,800 Nm



Features

- Easy to mount
- Compensation for shaft misalignment
- Adjustable torque settings

Material

- **Bellows:** high grade stainless steel
- **Torque limiter element:** hardened steel
- **Clamping hubs:** up to size 80 aluminum, size 150 and up steel

Design

Two clamping hubs with one clamping screw in each. Torque limiter system: spring loaded ball-detent principle. Operable temperature range from -30°C to +100°C.

Available function systems

- W = Single position / automatic re-engagement (standard)
- D = Multi-position / automatic re-engagement
- G = Load holding / load blocking
- F = Full disengagement / manual re-engagement

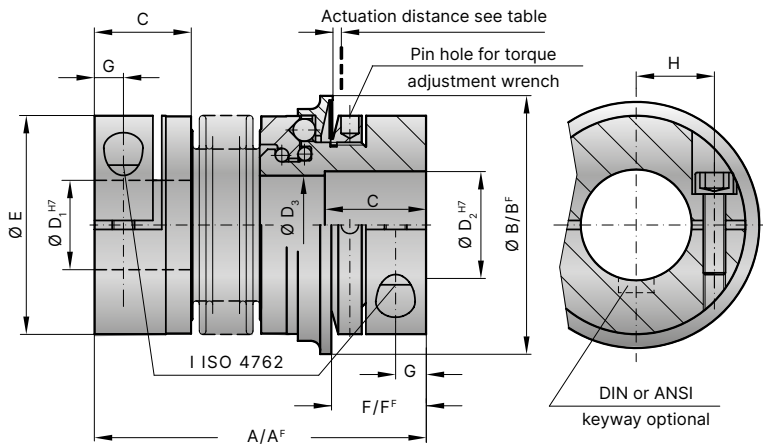

Model SK2

Size		1.5	2	4.5	10	15	30	60	80	150	200	300	500	800	1,500
Adjustment range available from - to (approx. values) (Nm)	T_{KN}	0.1-0.6 0.4-1 0.8-1.5	0.2-1.5 oder 0.5-2	1-3 oder 3-6	2-6 oder 4-12	5-10 oder 8-20	10-25 oder 20-40	10-30 oder 25-80	20-70 oder 30-90	20-70 oder 45-150 80-180	30-90 oder 60-160 120-240	100-200 oder 150-240 200-320	80-200 oder 200-350 300-500	400-650 oder 500-800 650-850	650-800 oder 1,000-1,200 1,000-1,800
Adjustment range available from - to (approx. values) ("F" Version) (Nm)	T_{KN}	0.3-0.8 or 0.6-1.3	0.2-1 or 0.7-2	2.5-4.5	2-5 oder 5-10	7-15	8-20 oder 16-30	20-40 oder 30-60	20-60 oder 40-80	20-60 oder 40-80 80-150	80-140 oder 130-200	120-180 oder 160-300	60-150 oder 100-300 250-500	200-400 oder 450-800	1,000-1,250 oder 1,250-1,500
Overall length (mm)	A	42	46 51	57 65	65 74	75 82	87 95	102 112	115 127	116 128	128 140	139 153	163 177	190	223
Overall length ("F" Version) (mm)	A ^F	42	46 51	57 65	65 74	75 82	87 95	102 112	117 129	118 130	131 143	142 156	167 181	201	232
Actuation ring Ø (mm)	B	23	29	35	45	55	65	73	92	92	99	120	135	152	174
Actuation ring Ø, ("F" Version) (mm)	B ^F	24	32	42	51.5	62	70	83	98	98	117	132	155	177	187
Clamping fit length (mm)	C	11	13	16	16	22	27	31	35	35	40	42	51	48	67
Inner diameter from Ø to Ø H7 (mm)	D ₁ /D ₂	3-8*	4-12*	5-14*	6-16*	10-26	12-30	15-32	19-42	19-42	24-45	30-60	35-60	40-75	50-80
Diameter (mm)	D ₃	9.1	12.1	14.1	20.1	21.1	24.1	32.1	36.1	36.1	42.1	58.1	60.1	60.1	68.1
Outside diameter of coupling (mm)	E	19	25	32	40	49	55	66	81	81	90	110	123	134	157
Distance (mm)	F	12	13	15	17	19	24	28	31	31	35	35	45	50	63
Distance, ("F" Version) (mm)	F ^F	11.5	12	14	16	19	22	29	31	30	33	35	43	54	61
Distance (mm)	G	3.5	4	5	5	6.5	7.5	9.5	11	11	12.5	13	17	18	22.5
Distance between centers (mm)	H	6	8	10	15	17	19	23	27	27	31	39	41	2x48	2x55
Screw ISO 4762	I	M2.5	M3	M4	M4	M5	M6	M8	M10	M10	M12	M12	M16	2xM16	2xM20
Tightening torque (Nm)	I	1	2	4	4.5	8	15	40	50	70	120	130	200	250	470
Approx. weight (kg)		0.047	0.07	0.2	0.3	0.4	0.6	1.0	2.0	2.4	4.0	5.9	9.6	14	21
Moment of inertia (10 ⁻³ kgm ²)	J _{ges}	0.01	0.01 0.01	0.020 0.02	0.06 0.07	0.10 0.15	0.27 0.32	0.75 0.80	1.80 1.90	2.50 2.80	5.10 5.30	11.5 11.8	22.8 23.0	42.0	83.0
Lateral ± (mm)	max.	0.15	0.15 0.20	0.20 0.25	0.20 0.30	0.15 0.20	0.20 0.25	0.20 0.25	0.20 0.25	0.20 0.25	0.25 0.30	0.25 0.30	0.30 0.35	0.35	0.35
Angular ± (degree)	values	1	1 1.5	1.5 2	1.5 2	1 1.5	1 1.5	1 1.5	1 1.5	1 1.5	1.5 2	1.5 2	2 2.5	2.5	2.5
Lateral spring stiffness (N/mm)		70	40 30	290 45	280 145	475 137	900 270	1,200 420	920 255	1,550 435	2,040 610	3,750 1,050	2,500 840	2,000	3,600
Actuation distance (mm)		0.7	0.8	0.8	1.2	1.5	1.5	1.7	1.9	1.9	2.2	2.2	2.2	2.2	3

A^F, B^F, L^F = Full disengagement / manual re-engagement version (F) Larger versions available upon request.

* keyway with max. bore only in clamping hub possible.

SL2

With clamping hubs

10 – 400 Nm



Features

- Easy to mount
- Compensation for shaft misalignment
- Adjustable torque settings
- Ultra compact, low inertia version

Design

Clamping collar / clamping hub with one clamping screw each.
Torque limiter system: spring loaded ball-detent principle.
Special compact, high stiffness version.
Operable temperature range from -30°C to +100°C.

Available function systems

- W = Single position / automatic re-engagement (standard)
- D = Multi-position / automatic re-engagement

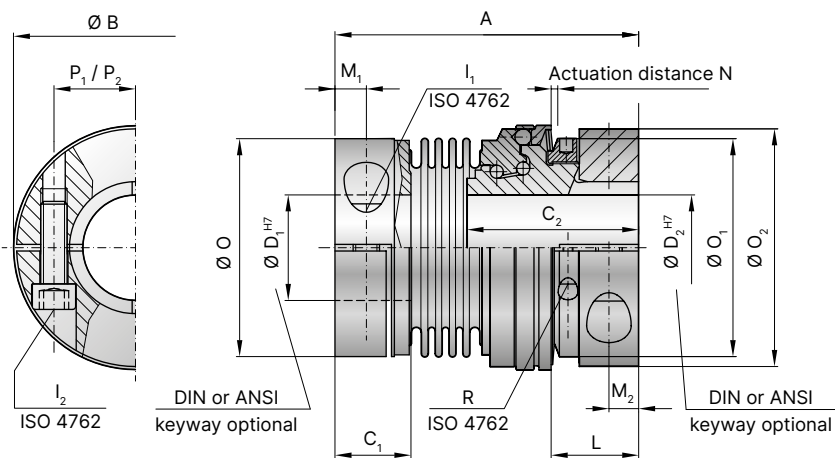

Light weight
safety coupling

Model SL2

Size			30	60	150	300
Adjustment range from - to	(Nm)	T_{KN}	10-35 30-80	20-50 40-100	40-100 100-200	100-250 200-350 300-400
Overall length	(mm)	A	80	93	112	126
Actuation ring diameter	(mm)	B	63	74	92	118
Hub length	(mm)	C_1/C_2	21/45	23/53	28 / 63	34/72
Inner diameter from \emptyset to \emptyset H7	(mm)	D_1/D_2	12-32/12-30	16-35 / 16-35	19-42 / 19-42	22-60 / 22-60
Screw ISO 4762	(mm)	I_1/I_2	M6	M8	M10	M12
Tightening torque	(Nm)		15	40	75	130
Distance to actuation ring edge	(mm)	L	22	26	32	35
Distance	(mm)	M_1/M_2	7.5/7.5	9.5/9	11/11	13/12
Actuation distance	(mm)	N	1.3	1.5	1.8	2
\emptyset Clamping hub \emptyset , (coupling end)	(mm)	O	55.5	66	82	110
\emptyset Adjustment nut	(mm)	O_1	55	66	82	100
Clamping ring \emptyset , (torque limiter end)	(mm)	O_2	59	72	90	112
Distance between centers, bellows side/safety element	(mm)	P_1/P_2	20/21.5	23 / 25	27/33	39/41
Adjustment nut's clamp screw ISO 4762		R	M3	M3	M3	M4
Tightening torque	(Nm)		2	2	2	4.5
Approx. weight	(kg)		0.4	0.7	1.2	2.8
Approx. moment of inertia at D max. (10^{-3} Kg m^2)		J_{ges}	0.2	0.8	1.4	6.2
Torsional stiffness	(10^3 Nm/rad)		31	72	141	157
Lateral \pm	max. (mm)		0.2	0.2	0.2	0.25

SKH

Backlash free torque limiters (with fully split clamping hub)

0.1 – 2,800 Nm



Features

- Radial mounting possible
- Very easy to mount and dismount
- Torque limiter system: spring loaded ball-detent principle

Material

- **Bellows:** high grade stainless steel
- **Torque limiter element:** hardened steel
- **Clamping hubs:** up to size 80 aluminum. size 150 and up steel

Design

Two clamping hubs with two clamping screw in each.
Torque limiter system: spring loaded ball-detent principle.

Available function systems

- W = Single position / automatic re-engagement (standard)
- D = Multi-position / automatic re-engagement
- G = Load holding / load blocking
- F = Full disengagement / manual re-engagement

Model SKH

SIZE			1.5	2	4.5	10	15	30	60
Adjustment range available from - to (approx. values)	(Nm)	T	0.1-0.6 0.4-1 0.8-1.5	0.2-1.5 or 0.5-2	1-3 or 3-6	2-6 or 4-12	5-10 or 8-20	10-25 or 20-40	10-30 or 25-80
Adjustment range available from - to (approx. values) ("F" Version)	(Nm)	T ^F	0.3-0.8 or 0.6-1.3	0.2-1 or 0.7-2	2.5-4.5	2-5 or 5-10	7-15	8-20 or 16-30	20-40 or 30-60
Overall length	(mm)	A	42	48 54	60 68	68 78	76 83	89 97	104 114
Distance	(mm)	H	27	30.5 36	37.5 45.5	45.5 55.5	46 53	54.5 62.5	62.5 72.5
Overall length ("F" Version)	(mm)	A ^F	42	48 54	60 68	68 78	76 83	89 97	104 114
Distance ("F" Version)	(mm)	H ^F	27	30.5 36	37.5 45.5	45.5 55.5	46 53	54.5 62.5	62.5 72.5
Actuation ring Ø	(mm)	B	23	29	35	45	55	65	73
Actuation ring Ø, ("F" Version)(mm)		B ^F	24	32	42	51.5	62	70	83
Clamping fit length	(mm)	C1	11	12.8	16	16	22	26.5	31
Clamping fit length	(mm)	C2	7.2	8.4	11.5	11.4	23.1	28.2	33
Inside diameter from Ø to Ø H7	(mm)	D1	3-8	4-12.7	5-16	5-20	10-28	10-30	14-35
Inside diameter from Ø to Ø H7 (with DIN 6885 keyway)	(mm)	D1 ^N	6-8	6-12.7	6-16	6-20	10-28	10-30	14-35
Inside diameter from Ø to Ø H7	(mm)	D2	4-8	4-12	5-14	5-20	10-26	10-30	14-32
Inside diameter from Ø to Ø H7 (with DIN 6885 keyway)	(mm)	D2 ^N	6	6-8	6-12	6-12	10-22	10-28	14-32
Diameter	(mm)	D3	6	8	12	12	21.1	24.1	32.1
Outside diameter of clamping hubs D1/D2	(mm)	E1/E2	21.2/20	25/27	32/32	40/40	49/49	55/55	66/66
Distance	(mm)	F	12.5-13.4	15.4-16.1	17.6-18.5	18.9-19.5	21.5-22.5	25.5-26.5	29-30
Distance ("F" Version)	(mm)	F ^F	12.5-13.4	14.8-15.5	17.4-18.2	18-19	21-22	23-25	27.5-29
Distance (approx. values)	(mm)	G1/G2	3.5/3.2	4.1/4.2	5.1/5.1	5.1/5.1	7/7	7.5/7.5	9.5/9.5
Distance between centers	(mm)	H1/H2	7.2/6.5	8/9.5	10.3/11	14.7/14.7	17.5/17.5	19/19	23.2/23.2
Screw ISO 4762	(mm)	I	4xM2.5	4xM3	4xM4	4xM4	4xM5	4xM6	4xM8
Tightening torque	(Nm)		1	2	4	4.5	8	15	40
Approx. weight	(kg)		0.047	0.07	0.2	0.3	0.4	0.6	1
Moment of inertia (10 ⁻³ kgm ²)		J _{ges}	0.01	0.01 0.01	0.02 0.02	0.06 0.07	0.10 0.15	0.27 0.32	0.75 0.80
Torsional stiffness (10 ³ Nm/rad)		CT	0.7	1.2 1.3	7 5	9 8	20 15	39 28	76 55
Lateral ± (mm)		max. values	0.15	0.15 0.20	0.20 0.25	0.20 0.30	0.15 0.20	0.20 0.25	0.20 0.25
Angular ± (degree)			1	1 1.5	1.5 2	1.5 2	1 1.5	1 1.5	1 1.5
Lateral spring stiffness (N/mm)			70	40 30	290 45	280 145	475 137	900 270	1,200 420
Actuation distance from EBS / from - to	(mm)	S	0.3-0.7	0.3-0.8	0.4-1	0.4-1	0.8-1.3	1-1.4	1.1-1.6

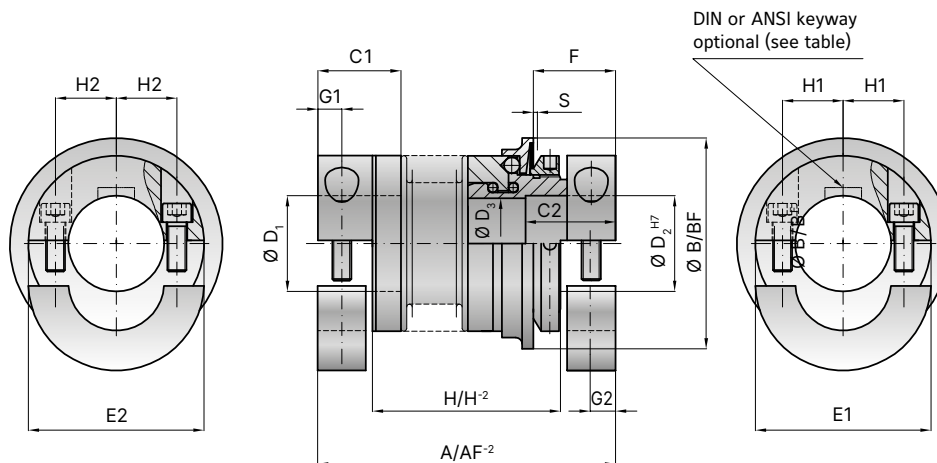

Model SKH

SIZE		150		200		300		500		800		1,500		2,500	
Adjustment range available from - to (approx. values)	(Nm)	T	20-70 45-150 80-180	30-90 60-160 120-240	100-200 150-240 200-320	80-200 200-350 300-500	400-600 500-800 650-850	650-800 700-1,200 1,000-1,800	1,500-2,000 2,000-2,500 2,300-2,800						
Adjustment range available from - to (approx. values) ("F" Version)	(Nm)	T ^F	20-60 40-80 80-150	80-140 or 130-200	120-180 or 160-300	60-150 100-300 300-500	200-400 or 450-800	1,000-1,250 or 1,250-1,500	1,400-2,200 or 1,800-2,700						
Overall length	(mm)	A	118 130	130.5 142.5	141 155	164 178	189	224.1	308						
Distance	(mm)	H	70 82	76.5 88.5	84.5 98.5	93 107	115	130.1	198						
Overall length ("F" Version)	(mm)	A ^F	120 132	134.5 146.4	143.5 157.5	169 183	201	236	314						
Distance ("F" Version)	(mm)	H ^F	72 84	80.5 92.5	87 101	98 112	126.5	142	204						
Actuation ring Ø	(mm)	B	92	99	120	135	152	174	243						
Actuation ring Ø, ("F" Version)	(mm)	B ^F	98	117	132	155	177	187	258						
Clamping fit length	(mm)	C1	35.5	40.5	42.5	50.5	45	65	82						
Clamping fit length	(mm)	C2	37	44	44.3	54.5	47.7	67	78.5						
Inside diameter from Ø to Ø H7	(mm)	D1	19-42	24-45	30-60	35-60	40-75	50-80	60-100						
Inside diameter from Ø to Ø H7 (with DIN 6885 keyway)	(mm)	D1 ^N	19-42	24-45	30-60	35-60	40-75	50-80	60-100						
Inside diameter from Ø to Ø H7	(mm)	D2	19-42	24-45	30-60	35-60	40-75	50-80	60-100						
Inside diameter from Ø to Ø H7 (with DIN 6885 keyway)	(mm)	D2 ^N	19-42	24-45	30-60	35-60	40-75	50-80	60-100						
Diameter	(mm)	D3	38.05	42.5	58	60.1	60.1	68.1	100.1						
Outside diameter of clamping hubs D1/D2	(mm)	E1/E2	81/81	90/90	110/110	122.5/122.5	132/132	157/157	198/198						
Distance	(mm)	F	32-33	36-37.5	38-40.5	47-49	49.5-51.5	60-62	81-83						
Distance ("F" Version)	(mm)	F ^F	33-35	36.5-40	36-39	48-51.5	53-57.5	59-63	79-83						
Distance (approx. values)	(mm)	G1/G2	12/11	12.5/12.5	14/13	16.8/16.8	17.5/17.5	22.5/22.5	26/26						
Distance between centers	(mm)	H1/H2	27.3/27.3	30.5/30.5	39/39	41/41	48/48	55/55	75/75						
Screw ISO 4762	(mm)	I	4xM10	4xM12	4xM12	4xM16	4xM16	4xM20	4xM20						
Tightening torque	(Nm)	I	70	120	130	200	250	470	500						
Approx. weight	(kg)		2.4	4	5.9	9.6	14	21	43						
Moment of inertia (10 ⁻³ kgm ²)	J _{ges}		2.5 2.8	5.1 5.3	11.5 11.8	22.8 23.0	42.0	83.0	348						
Torsional stiffness (10 ³ Nm/rad)	CT		175 110	191 140	420 350	510 500	780	1,304	3,400						
Lateral ± (mm)	max. values		0.20 0.25	0.25 0.30	0.25 0.30	0.30 0.35	0.35	0.35	0.35						
Angular ± (degree)			1 1.5	1.5 2	1.5 2	2 2.5	2.5	2.5	2.5						
Lateral spring stiffness (N/mm)			1,550 435	2,040 610	3,750 1,050	2,500 840	2,000	3,600	6,070						
Actuation distance from EBS / from - to	(mm)	S	1.1-1.7	1.7-2.3	1.8-2.4	1.9-2.6	1.7-2.5	2.4-3	2.8-3.2						

SK3

With conical clamping system

5 – 2,800 Nm



Features

- High clamping pressure
- Compensation for shaft misalignment
- Adjustable torque settings

Material

- **Bellows:** high grade stainless steel
- **Torque limiter element:** hardened steel
- **Clamping hubs / bushings:** steel

Design

Two conical clamping assemblies with six tightening screws each,

plus jack screws for removal. Torque limiter system : spring loaded ball-detent principle. Operable temperature range from -30°C to +100°C.

Available function systems

- W = Single position / automatic re-engagement (standard)
- D = Multi-position / automatic re-engagement
- G = Load holding / load blocking
- F = Full disengagement / manual re-engagement

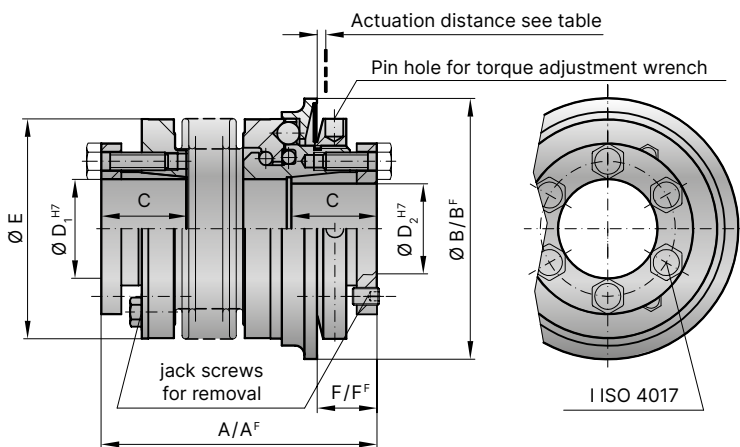

Model SK3

Size		15	30	60	150	200	300	500	800	1,500	2,500
Adjustment range available from (approx. values) (Nm)	T_{KN}	5-10 or 8-20	10-25 or 20-40	10-30 or 25-80	20-70 45-150 80-200	30-90 60-160 140-280	100-200 150-240 220-400	80-200 200-350 300-500	400-650 500-800 600-900	650-850 700-1,200 1,000-1,800	1,500-2,000 2,000-2,500 2,300-2,800
Adjustment range available from (approx. values) ("F" Version) (Nm)	T_{KN}	7-15	8-20 or 16-30	20-40 or 30-60	20-60 40-80 80-150	80-140 or 130-200	120-180 or 160-300	60-150 or 100-300 250-500	200-400 or 450-800	1,000-1,250 or 1,250-1,500	1,400-2,200 or 1,800-2,700
Overall length ±2 (mm)	A	62 69	72 80	84 94	93 105	99 111	114 128	123 136	151	175	246
Overall length ("F" Version) ±2 (mm)	A ^F	62 69	72 80	84 94	93 105	102 114	117 131	127 140	151	184	252
Actuation ring Ø (mm)	B	55	65	73	92	99	120	135	152	174	243
Actuation ring Ø, ("F" Version) (mm)	B ^F	62	70	83	98	117	132	155	177	187	258
Clamping fit length (mm)	C	19	22	27	32	32	41	41	49	61	80
Inner diameter from Ø to Ø H7 (mm)	D ₁ /D ₂	10-22	12-23	12-29	15-37	20-44	25-56	25-60	30-60	35-70	50-100
Outside diameter of coupling (mm)	E	49	55	66	81	90	110	123	133	157	200
Distance (mm)	F	13	16	18	19	19	23	25	31	30	34
Distance ("F" Version) (mm)	F ^F	13	14	17	18	17	20	22	20	26	31
6x Screw ISO 4017	I	M4	M5	M5	M6	M6	M8	M8	M10	M12	M16
Tightening torque (Nm)	I	4	6	8	12	14	18	25	40	70	120
Approx. weight (kg)		0.3	0.4	1.2	2.3	3.0	5.0	6.5	9.0	16.3	35
Moment of inertia (10 ⁻³ kgm ²)	J _{ges}	0.10 0.15	0.28 0.30	0.75 0.80	1.90 2.00	2.80 3.00	5.50 6.00	11.0 12.8	20	42	257
Lateral	max. values	0.15 0.20	0.20 0.25	0.20 0.25	0.20 0.25	0.25 0.30	0.25 0.30	0.30 0.35	0.35	0.35	0.35
Angular		1 1.5	1 1.5	1 1.5	1 1.5	1.5 2	1.5 2	2 2.5	2.5	2.5	2.5
Lateral spring stiffness		475 137	900 270	1,200 380	1,550 435	2,040 610	3,750 1,050	2,500 840	2,000	3,600	6,070
Actuation distance		1.5	1.5	1.7	1.9	2.2	2.2	2.2	2.2	3	3

A^F, B^F, L^F = Full disengagement / manual re-engagement version (F) Larger versions available upon request.

SK5

Blind mate with clamping hubs

0.1 – 850 Nm



Features

- Very easy to mount and dismount
- Electrically and thermally isolating
- Adjustable torque settings

Material

- **Bellows:** high grade stainless steel
- **Torque limiter element:** hardened steel
- **Clamping hubs:** up to size 80 aluminum, size 150 and up steel
- **Tapered male segment:** high strength plastic

Design

Two clamping hubs with one

clamping screw each, and one of the clamping hubs with tapered male segment for plug-in installation.
Torque limiter system: spring loaded ball-detent principle. Operable temperature range from -30°C to +100°C.

Available function systems

- W = Single position / automatic re-engagement (standard)
- D = Multi-position / automatic re-engagement
- G = Load holding / load blocking
- F = Full disengagement / manual re-engagement

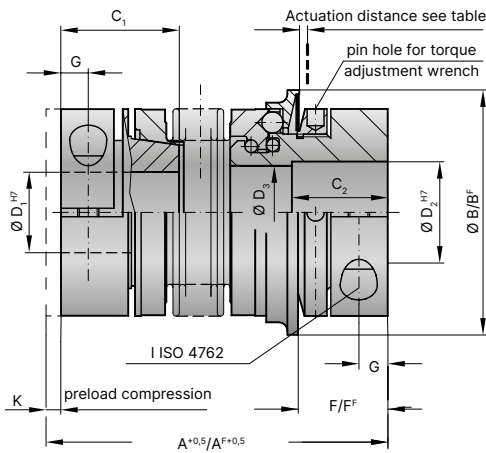

Multi position

Optional: Series 1.5 -800

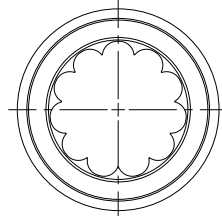

Six position

Standard: Series 15-800

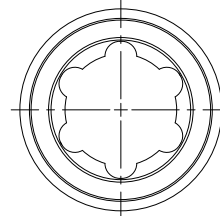

Single position

Standard: Series 1.5 – 10
Optional: Series 15-800

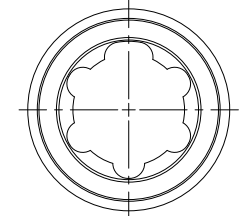

Model SK5

Size		1.5	2	4.5	10	15	30	60	80	150	300	500	800
Adjustment range available from - to (approx. values) (Nm)	T _{KN}	0.1-0.6 0.4-1 0.8-1.5	0.2-1.5 0.5-2	1-3 3-6	2-6 4-12	5-10 8-20	10-25 20-40	10-30 25-80	20-70 30-90	20-70 45-150	100-200 150-240 200-320	80-200 200-350 300-500	400-650 500-800 650-850
Adjustment range available from - to (approx. values) ("F" Version) (Nm)	T _{KN}	0.3-0.8 0.6-1.3	0.2-1 0.7-2	2.5-4.5	2-5 5-10	7-15	8-20 16-30	20-40 30-60	20-60 40-80	80-150	120-200 160-300	60-150 100-300 250-500	200-400 450-800
Overall length +0,5 (mm)	A	44	48 54	60 68	70 79	76 83	89 97	105 115	115 127	116 128	143 157	166 180	196
Overall length +0.5 ("F" Version) (mm)	A ^F	44	48 54	60 68	70 79	76 83	89 97	105 115	117 129	118 130	146 160	170 184	207
Actuation ring Ø (mm)	B	23	29	35	45	55	65	73	92	92	120	135	152
Actuation ring Ø, ("F" Version) (mm)	B ^F	24	32	42	51.5	62	70	83	98	98	132	155	177
Clamping fit length (mm)	C ₁ /C ₂	14 11	16 13	19 16	21 16	28 22	33 27	39 31	43 35	43 35	52 42	61 52	74 48
Inner diameter from Ø to Ø H7 (mm)	D ₁	3-8*	4-12*	5-16*	5-20*	8-22*	10-25*	12-32	14-38*	14-38*	30-56	35-60	40-62*
Inner diameter from Ø to Ø H7 (mm)	D ₂	3-8*	4-12*	5-14*	5-20*	8-26	10-30	12-32	14-42	14-42	30-60	35-60	40-75
Diameter (mm)	D ₃	9.1	12.1	14.1	20.1	21.1	24.1	32.1	36.1	36.1	58.1	60.1	60.1
Outside diameter (mm)	E	19	25	32	40	49	55	66	81	81	110	123	134
Distance (mm)	F	12	13	15	17	19	24	28	31	31	35	45	50
Distance ("F" Version) (mm)	F ^F	11.5	12	14	16	19	22	29	31	30	36	43	54
Distance (mm)	G	3.5	4	5	5	6.5	7.5	9.5	11	11	13	17	18
Distance between centers (mm)	H	6	8	10	15	17	19	23	27	27	39	41	2x48
Screw ISO 4762	I	M2.5	M3	M4	M4	M5	M6	M8	M10	M10	M12	M16	2xM16
Tightening torque (Nm)	I	1	2	4	4.5	8	15	40	50	70	130	200	250
Pretensioning, approx (mm)	K	0.1-0.5	0.2-0.7	0.2-0.7	0.2-1.0	0.2-1.0	0.3-1.5	0.5-1.5	0.5-1.0	0.5-1.0	0.5-1.5	0.5-2.0	0.8-2.0
Axial recovery of coupling max. (N)	K	4	8 5	15 10	25 30	20 12	50 30	70 45	48 32	82 52	157 106	140 96	200
Approx. weight (kg)		0.038	0.07	0.2	0.3	0.4	0.6	1.4	2	2.4	5.9	9.6	15
Moment of inertia (10 ⁻³ kgm ²)	J _{ges}	0.01	0.01 0.01	0.02 0.02	0.06 0.07	0.10 0.15	0.27 0.32	0.75 0.80	1.80 1.90	2.50 2.80	6.50 7.00	13.0 17.0	50
Lateral ± (mm) max. values		0.15	0.15 0.20	0.20 0.25	0.20 0.30	0.15 0.20	0.20 0.25	0.20 0.25	0.20 0.25	0.20 0.25	0.25 0.30	0.30 0.35	0.35
Angular ± (degree)		1	1 1.5	1.5 2	1.5 2	1 1.5	1 1.5	1 1.5	1 1.5	1 1.5	1.5 2	2 2.5	2.5
Lateral spring stiffness (N/mm)		70	40 30	290 45	280 145	475 137	900 270	1,200 420	920 290	1,550 435	3,750 1,050	2,500 840	2,000
Actuation distance (mm)		0.7	0.8	0.8	1.2	1.5	1.5	1.7	1.9	1.9	2.2	2.2	2.2

A^F, B^F, L^F = Full disengagement / manual re-engagement version (F) * keyway with max. bore only conditionally possible.

ES2

Press fit elastomer with clamping hub

1 – 1,800 Nm



Features

- Easy to mount
- Vibration damping
- Compensation for shaft misalignment
- Adjustable torque settings

Material

- **Torque limiter element:** hardened steel
- **Hub D1:** up to size 450 high strength aluminum, size 800 and up steel
- **Hub D2:** up to size 60 high strength aluminum, size 150 and up steel
- **Elastomer insert:** wear resistant thermally stable TPU

Information for elastomer inserts

See page 64

Design

Two clamping hubs with one clamping screw in each and concave driving jaws. Backlash free, vibration damping, electrically isolating elastomer insert press fit into the jaw sets. Torque limiter system: spring loaded ball-detent principle.

Available function systems

- W = Single position / automatic re-engagement (standard)
- D = Multi-position / automatic re-engagement
- G = Load holding / load blocking
- F = Full disengagement / manual re-engagement

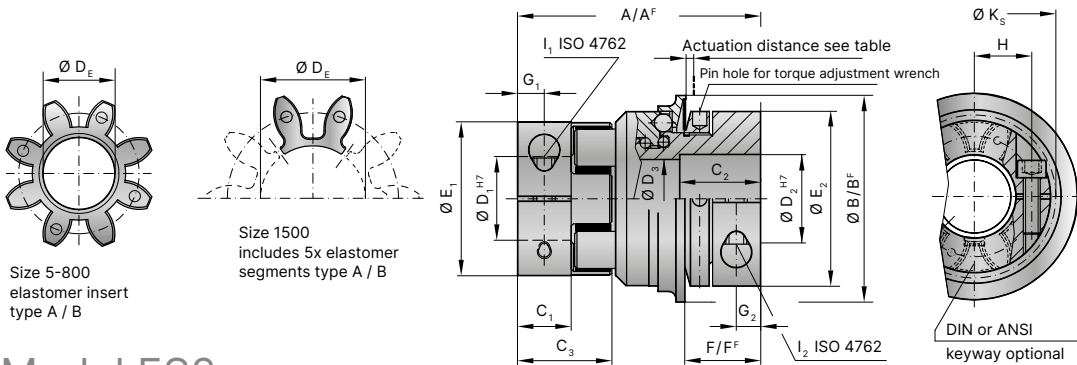

Model ES2

Size		5		10		20		60		150		300		450		800		1,500	
Type (Elastomer insert)		A	B	A	B	A	B	A	B	A	B	A	B	A	B	A	B	A	B
Rated torque	(Nm)	9 12		12.5 16		17 21		60 75		160 200		325 405		530 660		950 1,100		1,950 2,450	
Max. torque	(Nm)	18 24		25 32		34 42		120 150		320 400		650 810		1,060 1,350		1,900 2,150		3,900 4,900	
Adjustment range possible from -to	(Nm)	1-3 or 3-6		2 - 6 or 4 - 12		10 - 25 or 20 - 40		10 - 30 or 25 - 80		20 - 70 45 - 150 80 - 180		100 - 200 150 - 240 200 - 320		80 - 200 200 - 350 300 - 500		400 - 650 500 - 800 600 - 900		600 - 850 700 - 1,200 1,000 - 1,800	
Adjustment range ("F" Version) possible from -to	(Nm)	2.5 - 4.5		2 - 5 or 5 - 10		8 - 20 or 16 - 30		20 - 40 or 30 - 60		20 - 60 40 - 80 80 - 150		120 - 180 oder 180 - 300		60 - 150 100 - 300 250 - 500		200 - 400 or 450 - 800		1,000 - 1,250 or 1,250 - 1,500	
Overall length	(mm)	A	50	60	86	96	106	140	164	179	245								
Overall length ("F" Version)	(mm)	A _F	50	60	86	96	108	143	168	190	257								
Actuation ring Ø	(mm)	B	35	45	65	73	92	120	135	152	174								
Actuation ring Ø, ("F" Version)	(mm)	B _F	42	51.5	70	83	98	132	155	177	187								
Clamping fit length	(mm)	C ₁	8	10.3	17	20	21	31	34	46	88								
Fit length	(mm)	C ₂	14	16	27	31	35	42	51	67	120								
Length of hub	(mm)	C ₃	16.7	20.7	31	36	39	52	57	74	120								
Inner diameter from Ø to Ø H7	(mm)	D ₁	4 - 12.7	5 - 16	8 - 25	12 - 32	19 - 36	20 - 45	28 - 60	35 - 80	35 - 90								
Inner diameter from Ø to Ø H7	(mm)	D ₂	6 - 14	6 - 16	12 - 30	15 - 32	19 - 42	30 - 60	35 - 60	40 - 75	50 - 80								
Diameter Ø	(mm)	D ₃	14.1	20.1	24.1	32.1	36.1	58.1	60.1	60.1	68.1								
Inside diameter (Elastomer insert)	(mm)	D _E	10.2	14.2	19.2	26.2	29.2	36.2	46.2	60.5	79								
Diameter of the hub	(mm)	E ₁	25	32	42	56	66.5	82	102	136.5	160								
Diameter of the hub	(mm)	E ₂	19	40	55	66	81	110	123	132	157								
Distance	(mm)	F	15	17	24	28	31	35	45	50	63								
Distance, ("F" Version)	(mm)	F _F	14	16	22	29	30	35	43	54	61								
Distance	(mm)	G ₁	4	5	8.5	10	11	15	17.5	23	36								
Distance	(mm)	G ₂	5	5	7.5	9.5	11	13	17	18	22.5								
Distance between centers	(mm)	H ₁	8	10.5	15	21	24	29	38	50.5	2 × 57								
ISO 4762 clamping screw		M3	M4	M5	M6	M8	M10	M12	M16	4 × M16*									
Tightening torque	(Nm)	I ₁	2	4.5	8	15	35	70	120	290	300								
Distance between centers D2 side	(mm)	H ₂	10	15	19	23	27	39	41	48	2 × 55								
Screws (ISO 4762)		M4	M4	M6	M8	M10	M12	M16	2 × M16	2 × M20									
Tightening torque	(Nm)	I ₂	4	4.5	15	40	70	130	200	250	470								
Diameter with screwhead	(mm)	K _S	25	32	44.5	57	68	85	105	139	155								
Approx. weight	(kg)		0.2	0.3	0.6	1.0	2.4	5.8	9.3	14.3	26								
Moment of inertia (10 ⁻³ kgm ²)		J _{ges}	0.02	0.06	0.25	0.7	2.3	11	22	33.5	185								
Actuation distance	(mm)		0.8	1.2	1.5	1.7	1.9	2.2	2.2	2.2	3.0								

A^F, B^F, L^F = Full disengagement / manual re-engagement version (F) * keyway with max. bore only in clamping hub possible.

SLE

Press fit elastomer with clamping hub

10 – 700 Nm



Features

- Easy to mount
- Vibration damping
- Compensation for shaft misalignment
- Adjustable torque settings
- Ultra compact, low inertia version

Design

Clamping collar with clamping screw. Clamping hub with concave driving jaws and clamping screw. Backlash free, vibration damping, electrically

isolating elastomer insert press fitted into the jaw sets. Torque limiter system: spring loaded ball detent principle, in a special compact, low inertia design.

Available function systems

- W = Single position / automatic re-engagement (standard)
- D = Multi-position / automatic re-engagement

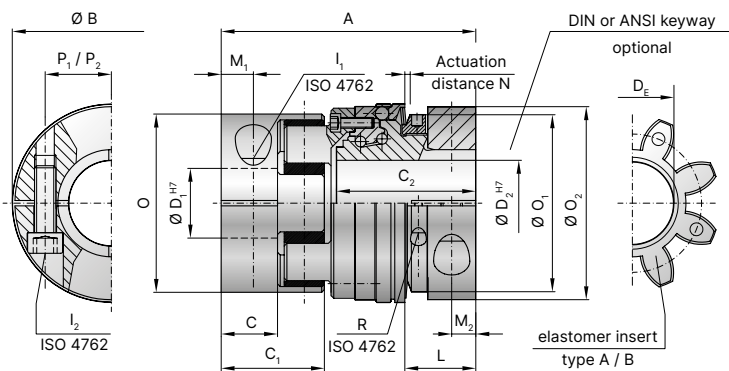

Light weight safety coupling

Model SLE

Size		30		60		150		300	
Type (elastomer insert)		A	B	A	B	A	B	A	B
Rated torque	T_{KN}	60	75	160	200	325	405	530	660
Max. torque	$T_{KN max}$	120	150	320	400	650	810	1,060	1,350
Adjustment range* possible from -to	(Nm) T_{KN}	10-35 30-80 40-135		30-80 60-120 100-200		40-100 100-200 150-300		200-350 300-450 400-550 550-700	
Overall length	(mm) A	85		93		122		135	
Actuation ring diameter	(mm) B	63		74		92		118	
Hub length (coupling hub end)	(mm) C/C ₁	20 / 36		21 / 39		31 / 52		34 / 57	
Length of hub (torque limiting portion)	(mm) C ₂	45		53		63		72	
Inner diameter from Ø to Ø H7	(mm) D ₁ /D ₂	12-32 / 12-30		16-36 / 16-35		19-45 / 19-42		22-60 / 22-60	
Inner diameter (elastomer insert)	(mm) D _E	26.2		29.2		36.2		46.2	
ISO 4762 screw, coupling side / torque limiter side	I ₁ /I ₂	M6		M8		M10		M12	
Tightening torque	(Nm)	15		40		75		130	
Distance to actuation ring edge	(mm) L	22		26		32		35	
Distance	(mm) M ₁ /M ₂	10 / 7.5		12 / 9		15 / 11		17.5 / 12	
Actuation distance	(mm) N	1.3		1.5		1.8		2	
Clamping hub Ø, elastomer coupling	O	56		66.5		82		102	
Ø Adjustment nut	O ₁	55		66		82		100	
Clamping hub Ø, safety coupling	O ₂	59		72		90		112	
Distance to clamping screw, coupling side / torque limiter side	P ₁ /P ₂	21 / 21.5		24 / 25		29 / 33		38 / 41	
Adjustment nut's clamp screw ISO 4762	R	M3		M3		M3		M4	
Tightening torque	(Nm)	2		2		2		4.5	
Approx. weight	(kg)	0.4		0.8		1.5		2.9	
Approx. moment of inertia at D max. (10 ⁻³ Kg·m ²)	J _{ges}	0.3		1		1.8		5	
Static torsional rigidity	(Nm/rad)	3,290	9,750	4,970	10,600	12,400	18,000	15,100	27,000
Dynamic torsional rigidity	(Nm/rad)	7,940	11,900	13,400	29,300	23,700	40,400	55,400	81,200
Lateral ±	approx. (mm)	0.12	0.1	0.15	0.12	0.18	0.14	0.2	0.18

SAFETY COUPLINGS
SK | SL | ES

ESL

With keyway connection

1 – 150 Nm



Features

- Low cost design
- Vibration damping
- Wear resistant ratcheting ball design

Material

- **The torque limiter element:** high strength steel, drive balls made from hardened steel
- **Hubs:** high strength aluminum
- **Elastomer insert:** wear resistant, thermally stable TPU

Information for elastomer inserts

See page 64

Design

Two hubs, each with keyway, set screw, and concave driving jaws. The torque limiter element is integrated into one of the hubs.

Disengagement

Negligible wear at up to 200 rpm. Contact R+W for higher speed applications.

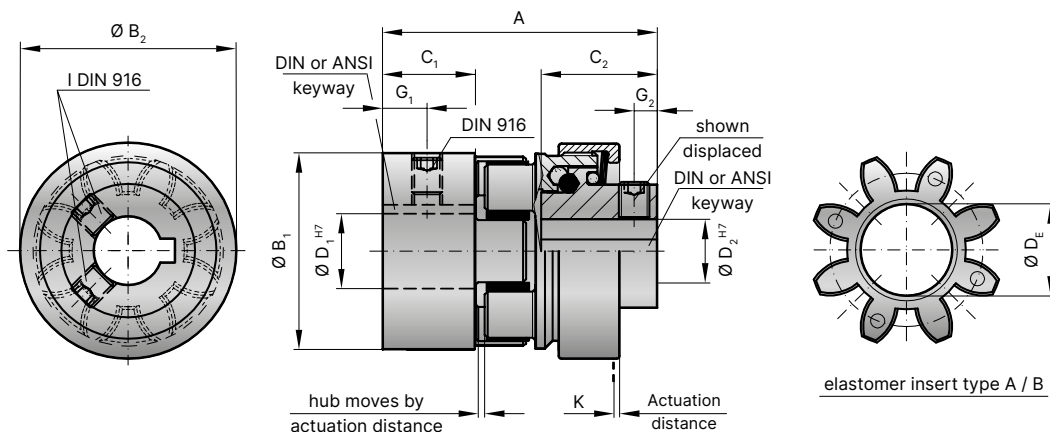

Model ESL

Size	5		10		20		60		150			
Type (Elastomer insert)			A	B	A	B	A	B	A	B		
Rated torque (Nm)	T_{kn}		9	12	12.5	16	17	21	60	75	160	200
Torque setting possible* from - to (Nm)	T_{kn}		1-6		1-12		3-19		5-60		20-150	
Overall length (mm)	A		34		45		64		80		90	
Diameter of the hub (mm)	B_1		25		32		42		56		66.5	
Diameter of the hub (mm)	B_2		29		32		46		59		75	
Clamping fit length (mm)	C_1		12.5		12		25		30		35	
Clamping fit length (mm)	C_2		11.5		20		22		31		35	
Inner diameter from Ø to Ø H7 (mm)	D_1		6-15		6-18		8-25		12-32		19-38	
Inner diameter from Ø to Ø H7 (mm)	D_2		6-10		6-12		8-19		12-24		19-32	
Inside diameter max. (elastomer) (mm)	D_E		10.5		14.2		19.2		26.2		29.2	
Distance (mm)	G_1		5		6		9		11		12	
Distance (mm)	G_2		2.5		3.5		4		4		4	
Screws DIN 916**	I		depending on bore diameter see below table									
Approx. weight (kg)			0.05		0.15		0.2		0.5		1	
Moment of inertia (10^{-3} kgm^2)	J_1 / J_2		0.01		0.02		0.08		0.15		0.5	
Actuation distance (mm)	K		0.6		0.6		0.7		1.1		1.4	

* Disengagement torque is permanently set at the factory.

Fixed disengagement torque

The ESL coupling is unlike other R+W safety couplings in that the disengagement torque is permanently set and tamper proof.

** Set screws

D1/D2	- Ø 10	Ø 11-12	Ø 13-30	Ø 31-58	Ø 59-80
I	M3	M4	M5	M8	M10

Bores <6mm made without keyway.

SK**ES2****SL**

Accessories safety coupling

Proximity switch

SK**ES 2**

Order number 650.2703.001

Technical data SK, ES2

Voltage	10 to 30 V DC
Max. output current	200 mA
Max. switch frequency	800 Hz
Temperature range	-25° to +70° C
Protective system	IP 67
Switch type	normally open
Max. detection gap	max. 2 mm

Switch diagram SK, ES2

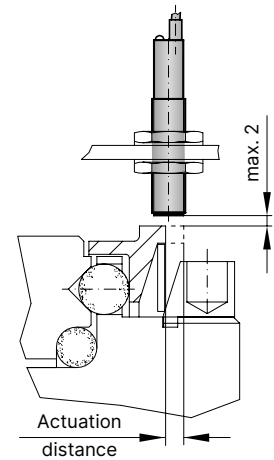
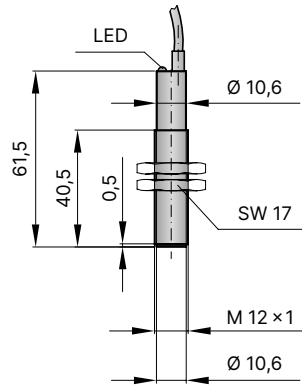
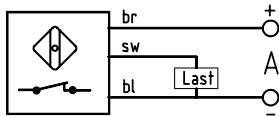
**SL**

Order number 619.4711.650

Technical data SL

Voltage	10 to 30 V DC
Max. output current	200 mA
Max. switch frequency	≤ 3 KHz
Temperature range	-25° to +70° C
Protective system	IP 67
Switch type	PNP, NO
Max. detection gap	max. 2 mm

Switch diagram SK, ES2

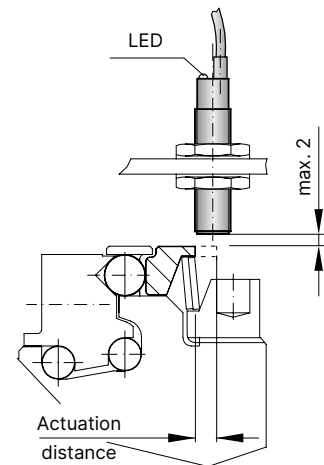
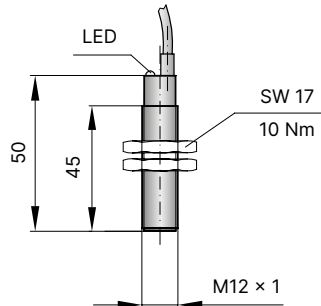
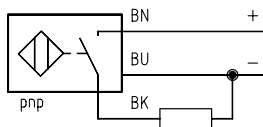

SK**ES2****SL**

Accessories safety coupling

Mechanical limit switch

SK**ES2****SL**

Order number 618.3000.313

Technical data SK, ES2, SL

Max. voltage 250 V AC

Protective system IP 67

Contact system 2 Opener (forced separating)

Temperature range -30° to +80° C

Actuation Plunger (metal)

Switch diagram SK, ES2, SL

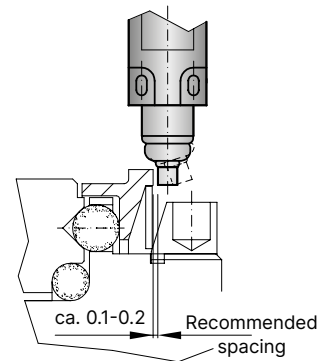
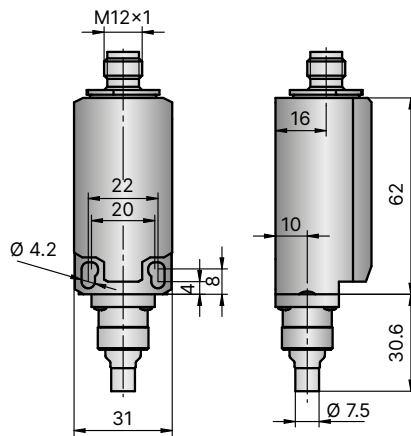
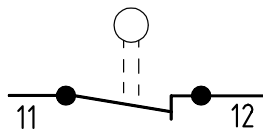

The mechanical limit switch is suitable for size 30 and up.
For smaller safety couplings the proximity sensor is recommended

The switch plunger (pictured above and right) should be located as close to the actuation ring / limit switch plate as possible (approximately 0.1-0.2mm).

SK

ES2

SL

Accessories safety coupling

R+W spanner wrench for torque adjustment

For smaller couplings the spanner wrench is not necessary. In sizes 1.5/2/4.5/10 the torque adjustment nut is easily turned with a screw or pin.

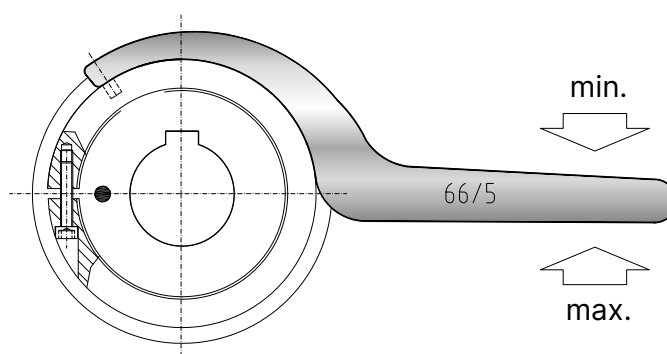

Order Numbers

Size	SK Single position Multi-position Load holding	SK Full disengagement	ES2 Single position Multi-position Load holding	ES2 Full disengagement	SL Single position Multi-position
15	49/4	49/4	-	-	-
20	-	-	55/4	55/4	-
30	55/4	55/4	-	-	55/4
60	66/5	66/5	66/5	66/5	66/5
80	82/5	82/5	-	-	-
150	82/5	82/5	82/5	82/5	82/5
200	90/6	98/5	-	-	-
300	114/6	114/6	114/6	114/6	100/6
450	-	-	126/8	126/8	-
500	126/8	126/8	-	-	-
800	134/8	144/8	134/8	144/8	-
1500	163/8	163/8	163/8	163/8	-
2500	210/10	226/10	-	-	-



ZA

EZ

Line shafts

9 – 25,000 Nm

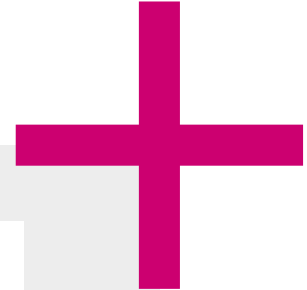

Areas of application

for spanning large distances between shaft ends in:

- + Material handling systems
- + Printing machinery
- + Packaging machinery
- + Theatre automation
- + Gantry systems
- + Screw jack systems

Service life

R+W line shafts are wear and maintenance free for an infinite service life, as long as the technical limits are not exceeded.

Fit clearance

Overall shaft / hub clearance of 0.01 - 0.05 mm

Rotational speed

After selecting overall length A, contact R+W for maximum speed.

Special solutions

Various materials, tolerances, dimensions and performance ratings available for custom applications on request.

ATEX (Optional)









Available on request.

Ordering example	ZA / EZ	30	1551	18	19	XX
Model	•					Special designation only (e.g. special bore tolerance).
Size		•				
Overall length mm			•			
Bore D1 H7				•		
Bore D2 H7					•	

For custom features place an XX at the end of the part number and describe the special requirements (e.g. ZA / 30 / 1551 / 18 / 19 / XX; XX=anodized aluminum)

ZA



Backlash free, torsionally stiff line shafts 10 – 4,000 Nm

Model	Features	Page
 	With clamping hub 10 – 800 Nm <ul style="list-style-type: none">• Installation and removal possible without disturbing other machine components• Standard lengths up to 6 meters• No intermediate support bearings required	106
 	With conical clamping system 1,500 – 4,000 Nm <ul style="list-style-type: none">• Installation and removal possible without disturbing other machine components• Standard lengths up to 6 meters• No intermediate support bearings required	107
 	With split clamping hub 10 - 800 Nm <ul style="list-style-type: none">• Complete coupling system mounts laterally for very easy installation and removal• Standard lengths up to 6 meters• No intermediate support bearings required	108
 	CFK intermediate tube with split clamping hub 10 – 800 Nm <ul style="list-style-type: none">• Complete coupling system mounts laterally for very easy installation and removal• Standard lengths up to 4 meters, with CFK tube• No intermediate support bearings required	109

EZ

Backlash free line shafts

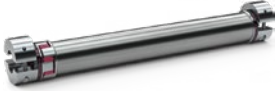
9 – 25,000 Nm

Model	Features	Page
 EZ2	With split clamping hub 9 – 25,000 Nm <ul style="list-style-type: none">• Standard lengths up to 4 meters• No intermediate support bearings required• Complete coupling system mounts laterally for very easy installation and removal	110-111
 EZ2 S	With rigid hub on one end 12.5 – 1,350 Nm <ul style="list-style-type: none">• Complete coupling system mounts laterally for very easy installation and removal• Standard lengths up to 4 meters• For use with intermediate bearing (ZL)	112
 EZV	With split clamping hub, adjustable length 12.5 – 2,150 Nm <ul style="list-style-type: none">• Adjustable length ranges up to 4 meters• No intermediate support bearings required• Complete coupling system mounts laterally for very easy installation and removal	114-115
Accessories		113

ZA

With clamping hub

10 – 800 Nm

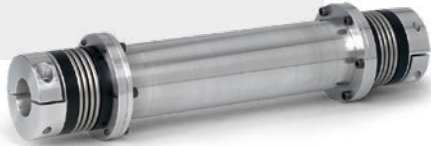

Features

- For spanning larger distances between shaft ends
- Standard lengths up to 6 meters
- No intermediate support bearings required
- Extremely straight and laterally stiff intermediate tube

Material

- **Bellows:** high grade stainless steel
- **Intermediate tube:** up to size 150 aluminum, size 300 and up steel, optional CFK
- **Hubs:** up to size 60 aluminum, size 150 and up steel

Design

Two clamping hubs with a single clamping screw in each. A special support system carries the weight of the tube on the hubs. Operable temperature range from -30°C to +100°C.

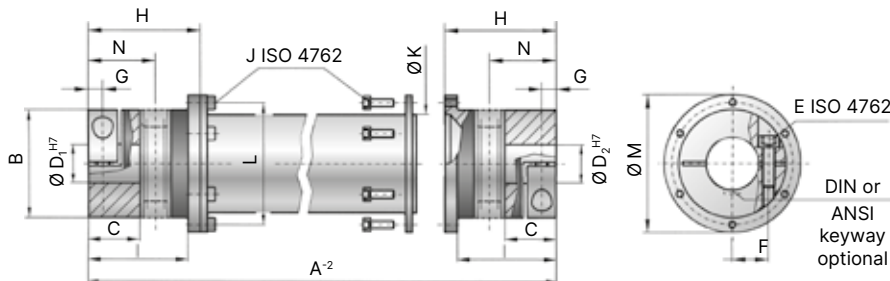

Vertical installation

ZA

ZAE

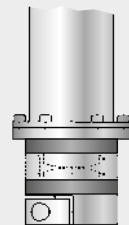

Schematic of support system

- In vertical installations a special support transfers the weight to the bottom hub.
- This support system is available for all sizes.
- Please note, "for vertical installation" when ordering.

Model ZA

Size			10	30	60	150	200	300	500	800
Rated torque	(Nm)	T_{KN}	10	30	60	150	200	300	500	800
Overall length min. to max.	(mm)	A^{-2}	110 - 6,000	140 - 6,000	170 - 6,000	215 - 6,000	210 - 6,000	250 - 6,000	260 - 6,000	260 - 6,000
Outside diameter clamping hub (mm)	B		40	55	66	81	90	110	123	134
Fit length	(mm)	C	16	27	31	35.5	40.5	43	50	48
Inside diameter from \varnothing to \varnothing H7	(mm)	$D_{1/2}$	5 - 20	10 - 28	12 - 32	19 - 42	22 - 45	30 - 60	35 - 60	40 - 72
With keyway max. \varnothing H7	(mm)	$D_{1/2}$	17	23	29	36	45	60	60	66
ISO 4762 clamping screw		E	M4	M6	M8	M10	M12	M12	M16	2x M16
Tightening torque	(Nm)		5	15	40	70	110	130	200	250
Distance between centers	(mm)	F	15	19	23	27	31	39	41	48
Distance	(mm)	G	5	7.5	9.5	11	12.5	13	17	18
Length bellows body	(mm)	H	44.5	57.5	71	78	86	94	110	101
Distance	(mm)	I	38.5	51	61	69	75.5	81	96	89
ISO 4762 clamping screw		J	4x M4	6x M4	6x M5	8x M6	8x M6	8x M8	8x M8	10x M8
Tightening torque	(Nm)		3	4	7	10	12	30	30	40
Outside diameter tube section (mm)	K		35	50	60	76	90	100	110	120
Bolt hole circle \varnothing	(mm)	L	45	62.5	71.5	88	100	120	132	138
Outside diameter flange	(mm)	M	52	70	80	98	110	135	148	153
Shaft average value	(mm)	N	25	34	41	47	52	56	66	64

ZA

With conical clamping system

1,500 - 4,000 Nm



Features

- For spanning larger distances between shaft ends
- Standard length up to 6 meters
- No intermediate support bearings required
- Extremely straight and laterally stiff intermediate tube

Material

- **Bellows:** high grade stainless steel
- **Intermediate tube:** steel, optional CFK
- **Hubs:** steel

Design

Two conical clamping bushings with separate screws for mounting and dismantling. A special support system carries the weight of the tube on the hubs. Operable temperature range from -30°C to +100°C.

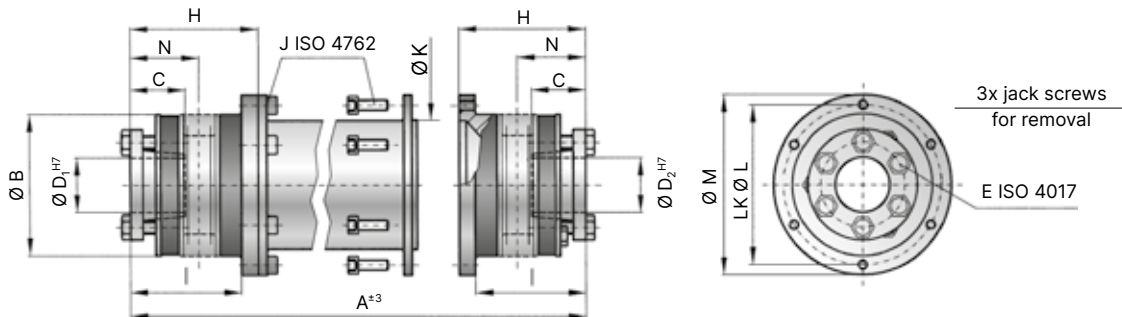

Model ZA

Size			1,500	4,000
Rated torque	(Nm)	T _{KN}	1,500	4,000
Overall length min. to max.	(mm)	A ⁺³	280 - 6,000	280 - 6,000
Outside diameter	(mm)	B	157	200
Fit length	(mm)	C	61	80.5
Inside diameter from Ø to Ø H7	(mm)	D _{1/2}	35 - 70	40 - 100
ISO 4017 clamping screws			6 x M12	6 x M16
Tightening torque	(Nm)	E	70	120
Length bellows body	(mm)	H	98	103.5
Distance	(mm)	I	82	84
ISO 4762 clamping screw			10x M10	12x M12
Tightening torque	(Nm)	J	70	120
Outside diameter tube section	(mm)	K	150	160
Bolt hole circle Ø	(mm)	L	168	193
Outside diameter flange	(mm)	M	184	213
Shaft average value	(mm)	N	56	61

ZAE

With split clamping hub

10 – 800 Nm



Features

- For spanning larger distances between shaft ends
- Standard length up to 6 meters
- No intermediate support bearings required
- Extremely straight and laterally stiff intermediate tube

Material

- **Bellows:** high grade stainless steel
- **Intermediate tube:** up to size 150 aluminum, size 300 and up steel
- **Hubs:** up to size 60 aluminum, size 150 and up steel

Design

Two clamping hubs with two clamping screws in each. A special support system carries the weight of the tube on the hubs. Operable temperature range from -30 to +100 °C.

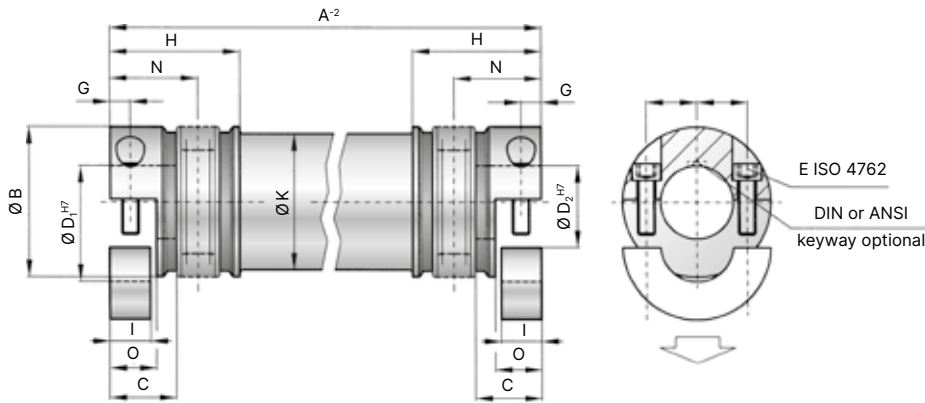

Vertical installation

ZA

ZAE

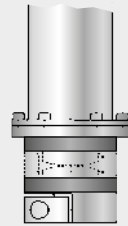

Schematic of support system

- In vertical installations a special support transfers the weight to the bottom hub.
- This support system is available for all sizes.
- Please note, "for vertical installation" when ordering.

Model ZAE

Size			10	30	60	150	300	500	800
Rated torque	(Nm)	T _{KN}	10	30	60	150	300	500	800
Overall length min. to max.	(mm)	A ²	100 - 6,000	130 - 6,000	160 - 6,000	180 - 6,000	240 - 6,000	250 - 6,000	250 - 6,000
Outside diameter clamping hub	(mm)	B	40	55	66	81	110	123	133
Fit length	(mm)	C	16	27	31	34.5	42	50	47
Inside diameter from Ø to Ø H7	(mm)	D _{1/2}	5 - 20	10 - 28	12 - 32	19 - 42	30 - 60	35 - 60	40 - 72
Max. inside diameter clamping hub	(mm)	D _{max}	24	30	32	42	60	60	75
With keyway - max Ø H7	(mm)	D _{1/2}	17	23	29	36	60	60	66
With keyway - max Ø H7		E	M4	M6	M8	M10	M12	M16	M16
Tightening torque	(Nm)		5	15	40	70	130	200	250
Distance between centers	(mm)	F	15	19	23	27	39	41	48
Distance	(mm)	G	5	7.5	9.5	12	14	17	19
Length bellows body	(mm)	H	39.5	52	64	72	83	96	95
Clamping length	(mm)	I	10	15	19	22	28	33.5	37.5
Outside diameter tube section	(mm)	K	35	50	60	76	100	110	120
Length	(mm)	O	11.5	17	21	24	30	35.5	40
Shaft average value	(mm)	N	25	34	41	47	56	66	65

ZAL

With CFK intermediate tube and split clamping hub

10 – 800 Nm



Features

- For high speeds
- Low moment of inertia
- High torsional stiffness
- Capable of spanning long distances
- Standard lengths up to 4m, special lengths on request
- No intermediate support bearing required

Material

- **Bellows:** high grade stainless steel
- **Intermediate tube:** CFK
- **Hubs:** up to size 60 aluminum, size 150 and up steel

Design

Two clamping hubs with two clamping screws in each. A special support system carries the weight of the tube on the hubs. Operable temperature range from -30°C to +100°C.

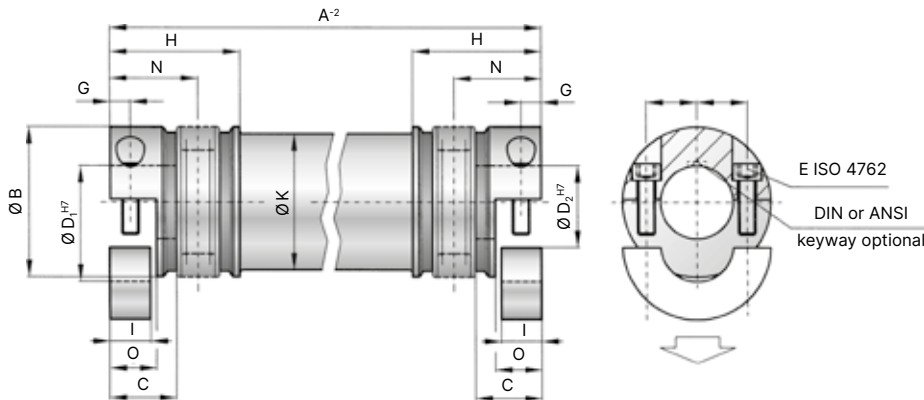

Model ZAL

Size			10	30	60	150	300	500	800
Rated torque (Nm)	T_{KN}		10	30	60	150	300	500	800
Overall length min. to max. (mm)	A^{-2}		110-2,000	150-4,000	190-4,000	210-4,000	260 - 4,000	320 - 4,000	340 - 4,000
Outside diameter clamping hub (mm)	B		40	55	66	81	110	123	133
Fit length (mm)	C		16	27	31	34.5	42	50	47
Inside diameter from Ø to Ø H7 (mm)	$D_{1/2}$		5 - 20	10 - 28	12 - 32	19 - 42	30 - 60	35 - 62	40 - 72
Max. inside diameter clamping hub (mm)	D_{max}		24	30	32	42	60	60	75
With keyway - max Ø H7 (mm)	$D_{1/2}$		17	23	29	36	60	62	66
ISO 4762 clamping screw	E		M4	M6	M8	M10	M12	M16	M16
Tightening torque (Nm)			5	15	40	70	130	200	250
Distance between centers (mm)	F		15	19	23	27	39	41	48
Distance (mm)	G		5	7.5	9.5	12	14	17	19
Length bellows body (mm)	H		40	52	66	73	80.5	95	100
Clamping length (mm)	I		10	15	19	22	28	33.5	37.5
Outside diameter tube section (mm)	K		35	52	63	79	102.5	115	127
Length (mm)	O		11.5	17	21	24	30	35	40
Shaft average value (mm)	N		25	34	41	47	56	66	65

EZ2

With split clamping hub

9 – 25,000 Nm



Features

- Easy installation and removal
- Standard length up to 4 meters
- No intermediate support bearings required

Material

- **Hubs:** up to size 450 high strength aluminum, size 800 steel, size 2500 and up GGG40
- **Intermediate tube:** up to size 450 high strength aluminum, size 800 and up steel, optional CFK tube on request
- **Elastomer insert:** wear resistant, thermally stable TPU

Design

Two split clamping hubs, with two clamping screws in each, and concave driving jaws. Backlash free, vibration damping, electrically isolating elastomer inserts press fit into the hubs. Precision intermediate tube with a high level of straightness and lateral stiffness.

Design | Size 15 - 800

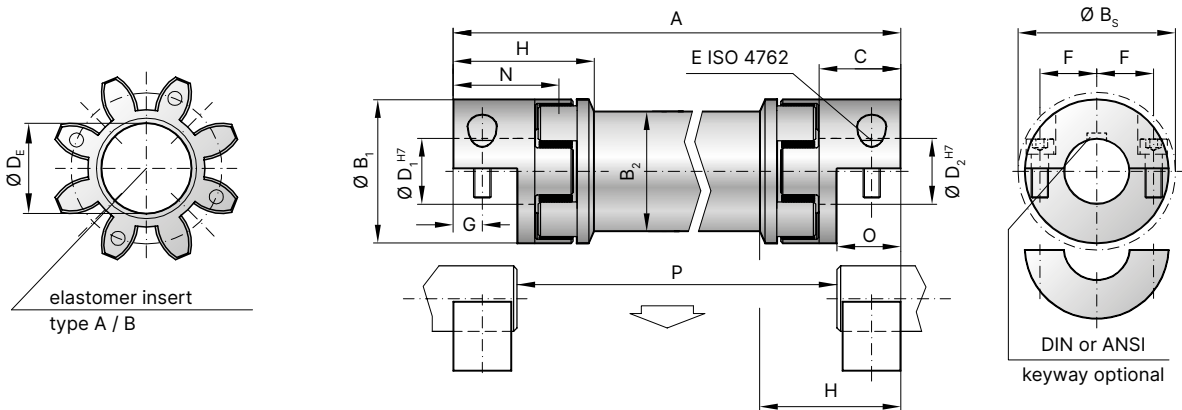

Design | Size 2,500 - 9,500

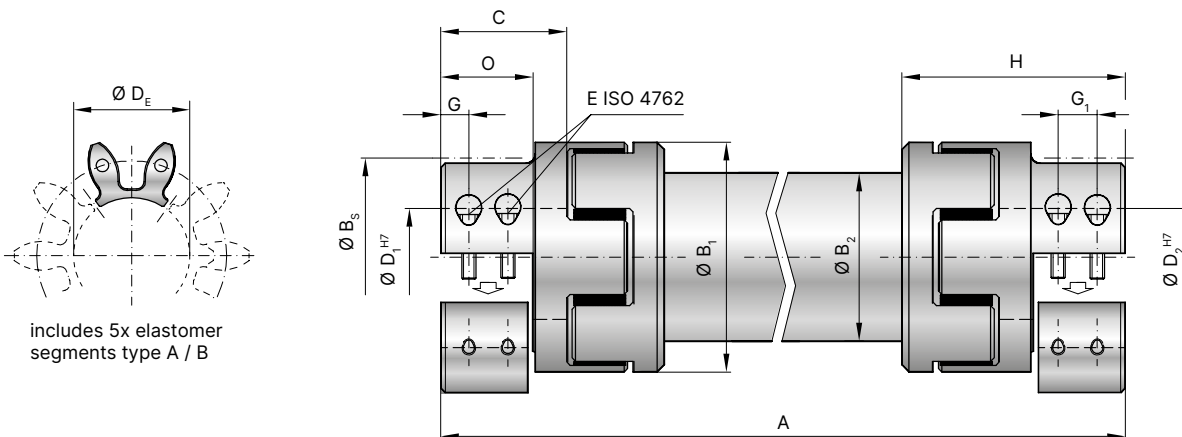

includes 5x elastomer segments type A / B

Model EZ2

Size		5		10		20		60		150		300		450		800		2,500		4,500		9,500	
Type (Elastomer insert)		A	B	A	B	A	B	A	B	A	B	A	B	A	B	A	B	A	B	A	B	A	B
Rated torque (Nm)	T_{KN}	9	12	12,5	16	17	21	60	75	160	200	325	405	530	660	950	1,100	1,950	2,450	5,000	6,200	10,000	12,500
Max. torque (Nm)	T_{Kmax}	18	24	25	32	34	42	120	150	320	400	650	810	1,060	1,350	1,900	2,150	3,900	4,900	10,000	12,400	20,000	25,000
Overall length (mm)	A	75-2,000		95 - 4,000		130 - 4,000		175 - 4,000		200 - 4,000		245 - 4,000		280 - 4,000		320 - 4,000		460 - 4,000		580 - 4,000		710 - 4,000	
Outside diameter hub (mm)	B_1	25		32		42		56		66.5		82		102		136.5		160		225		290	
Outside diameter tube (mm)	B_2	25		28		35		50		60		76		90		120		150		175		220	
Outside diameter with screwhead (mm)	B_s	25		32		44.5		57		68		85		105		139		155		199		243	
Fit length (mm)	C	13		20		25		40		47		55		65		79		88		113		142	
Inside diameter from \emptyset to \emptyset H7 (mm)	$D_{1/2}$	5 - 12.7		5 - 16		8 - 25		14 - 32		19 - 36		19 - 45		24 - 60		35 - 80		35 - 90		40 - 120		50 - 140	
Max. inside diameter (Elastomer insert)(mm)	D_E	10.2		14.2		19.2		26.2		29.2		36.2		46.2		60.5		80		111		145	
ISO 4762 clamping screw	E	4 x M3		4 x M4		4 x M5		4 x M6		4 x M8		4 x M10		4 x M12		4 x M16		8x M16		8 x M20		8 x M24	
Tightening torque(Nm)		2		4		8		15		35		70		120		290		300		600		980	
Distance between centers (mm)	F	8		10.5		15.5		21		24		29		38		50.5		57		75		90	
Distance (mm)	G/G ₁	5		7.5		8.5		15		17.5		20		25		30		18 / 30		24 / 41		30 / 48	
Coupling length (mm)	H	25		34		46		63		73		86		98		129		142		181		229	
Moment of inertia per hub (10^{-3} kgm ²)	J_1/J_2	0.004		0.01		0.02		0.15		0.21		1.02		2.3		17		30		140		450	
Inertia of tube per meter (10^{-3} kgm ²)	J_3	0.049		0.075		0.183		0.66		1.18		2.48		10.6		38		360		750		1,800	
Combined dynamic torsional stiffness of the inserts (Nm/rad)	C_{Tdyn}^E	150	350	270	825	1,270	2,220	3,970	5,950	6,700	14,650	11,850	20,200	27,700	40,600	41,300	90,000	87,500	108,000	168,500	371,500	590,000	670,000
Torsional stiffness of tube per meter (Nm/rad)	C_T^{ZWR}	503		727		1,770		6,440		11,500		24,000		73,000		389,000		950,000		2,200,200		5,500,000	
Shaft average value (mm)	N	18		26		33		49		57		67		78		94		108		137		171	
Length (mm)	O	11		16.6		18.6		32		37		42		52		62		67		85		105	
Length of hub (mm)		25		34		46		63		73		86		98		129		142		181		229	

Installation

The overall length A is best determined as the distance between shaft ends P plus 2x dimension O.

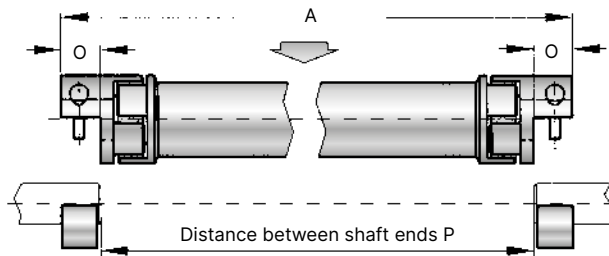

EZ2 S

With rigid hub on one end

12.5 – 1,350 Nm

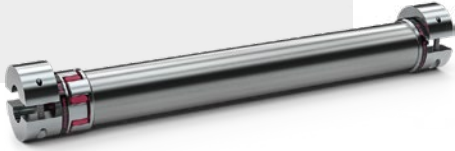

Features

- Easy lateral installation without the need to disturb adjacent shafts
- Standard lengths up to 4m
- For use with intermediate support bearing (ZL)

Material

- **Hubs:** high strength aluminum
- **Intermediate tube:** high strength aluminum
- **Elastomer insert:** wear resistant, thermally stable TPU

Design

Two split clamping hubs, with two clamping screws in each, and concave driving jaws on one end, with rigid hub on the other. Backlash free, vibration damping, electrically isolating elastomer insert press fit into the jaw hub. Precision intermediate tube with a high level of straightness and lateral stiffness.

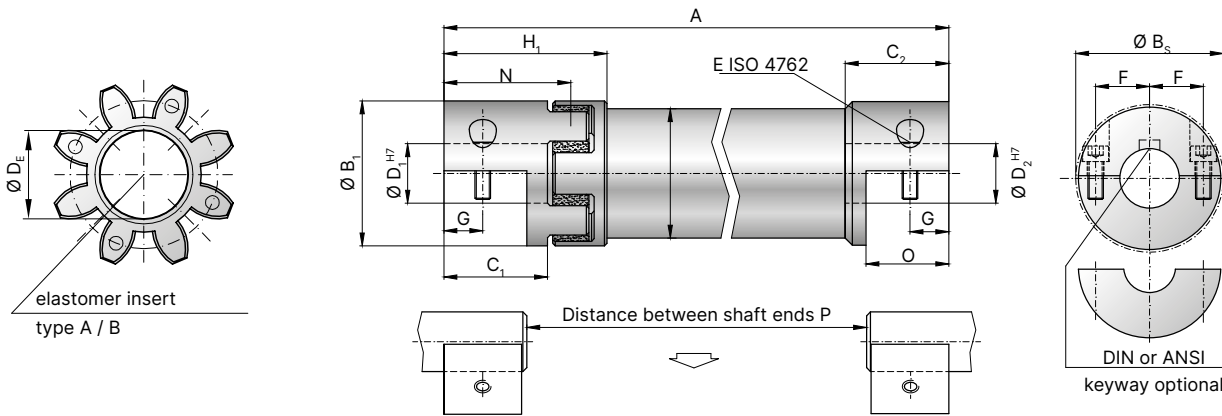

The total length A is calculated by adding distance between shaft ends P + 2xO

Intermediate support bearing and intermediate shaft available as accessories in various sizes.

Model EZ2 S

Size		10		20		60		150		300		450	
Type (Elastomer insert)		A	B	A	B	A	B	A	B	A	B	A	B
Rated torque (Nm)	T_{KN}	12.5	16	17	21	60	75	160	200	325	405	530	660
Max. torque (Nm)	T_{Kmax}	25	32	34	42	120	150	320	400	650	810	1,060	1,350
Overall length from - to (mm)	A	85 - 4,000		115 - 4,000		155 - 4,000		175 - 4,000		220 - 4,000		250 - 4,000	
Outside diameter hub (mm)	B_1	32		42		56		66.5		82		102	
Outside diameter tube section (mm)	B_2	28		35		50		60		76		90	
Outside diameter with screwhead (mm)	B_s	32		44.5		57		68		85		105	
Fit length (mm)	C_1/C_2	20		25		40		47		55		65	
Inside diameter from \varnothing to $\varnothing H7$ (mm)	D_1/D_2	5 - 16		8 - 25		14 - 32		19 - 36		19 - 45		24 - 60	
ISO 4762 clamping screw	E	4 x M4		4 x M5		4 x M6		4 x M8		4 x M10		4 x M12	
Tightening torque (Nm)		4		8		15		35		70		120	
Distance between centers (mm)	F_1/F_2	10.5		15.5 / 15		21		24		29		38	
Distance (mm)	G_1/G_2	7.5		8.5		15		17.5		20		25	
Coupling length (mm)	H	34		46		63		73		84		97	
Shaft average value (mm)	N	26		33		49		57		67		78	
Length (mm)	O	16.6		18.6		32		37		42		52	

ZA

EZ

Accessories for ZA/EZ

ZL Intermediate support bearing

ZL

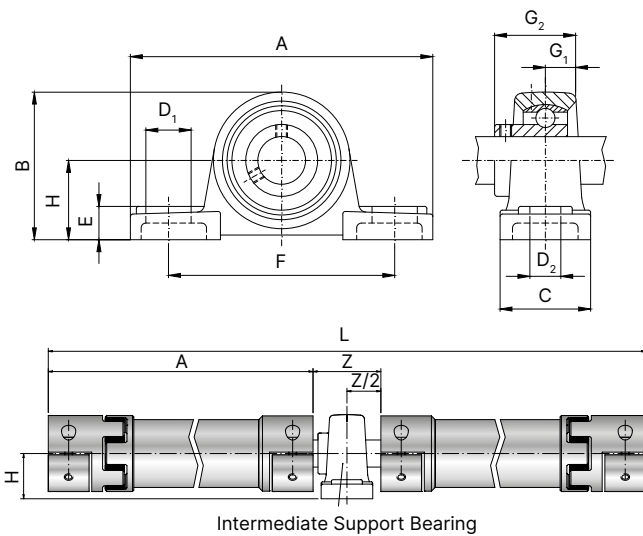

Intermediate Support Bearing

The Intermediate Support Bearing (ZL) in combination with the line shafts of the series ZA and EZ for special installation situations.

Intermediate support bearing ZL

Size	(mm)	15	20	30	40	50	
Length	(mm)	A	127	127	163	178	206
Height	(mm)	B	62	65	82	97	113
Width	(mm)	C	38	38	46	52	60
Mounting dimension	(mm)	D ₁	19	19	21	21	23
Mounting dimension	(mm)	D ₂	13	13	17	17	20
Mounting dimension	(mm)	E	14	14	17	18	21
Hole spacing	(mm)	F	95	95	121	136	159
Distance	(mm)	G ₁	12.7	12.7	15.9	19	19
Distance	(mm)	G ₂	31	31	38.1	49.2	51.6
Distance	(mm)	H	30.2	33.3	42.9	49.2	57.2

Intermediate Support Bearing	202	204	206	208	210
------------------------------	-----	-----	-----	-----	-----

Ordering Example

Model	ZL	15
Size		

ZW Intermediate shaft

ZW

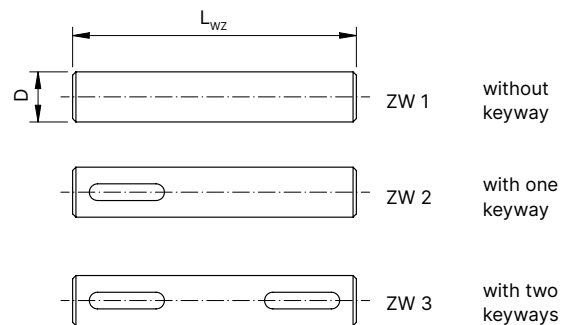

Intermediate shaft (SW) for Intermediate Support Bearing (ZL) in conjunction with ZA and EZ Line Shafts. Steel construction.

The intermediate shaft ZW 1 comes without keyways, the intermediate shaft ZW 2 has one keyway and the intermediate shaft ZW 3 has two keyways.

Keyways are machined to DIN 6885 standard.

Intermediate support bearing ZW

Size (ShaftØ)	(mm)	D	15	20	30	40	50
Length	(mm)	L _{wz}	130	140	165	195	210
Intermediate Support Bearing	202	204	206	208	210		

Ordering Example

Model	ZW	2	15
Intermediate Shaft Style			
Size			



Adjustable length with split clamping hub

12.5 – 2,150 Nm



Features

- Telescoping for adjustable length and rotational orientation
- Very easy to install and remove
- No intermediate support bearings required
- Length ranges up to 4 meters

Material

- **Hubs:** high strength aluminum
- **Intermediate tube:** highly straight and concentric aluminum tubing
- **Elastomer insert:** wear resistant, thermally stable TPU

Design

Two split clamping hubs, with two clamping screws in each, and concave driving jaws. Backlash free, vibration damping, electrically isolating elastomer inserts press fit into the hubs. Precision intermediate tube with a high level of straightness and lateral stiffness. Outer tube clamps over inner tube to fix the overall length.

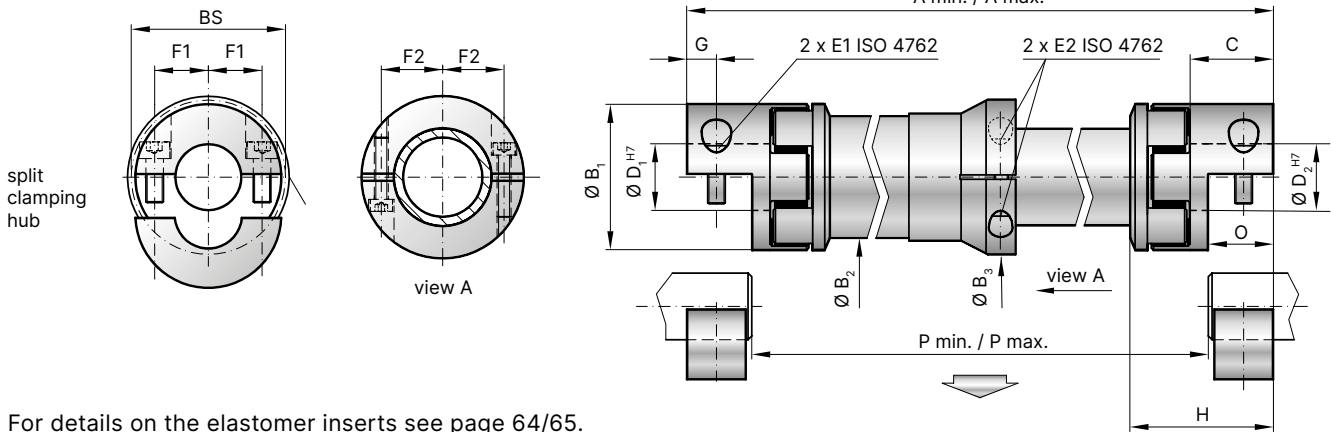

For details on the elastomer inserts see page 64/65.

Functional Description

The maximum extended length relates to the minimum collapsed length. The formulas to the right can be used to determine the corresponding values.

$$\text{Maximum extended length} = (\text{collapsed length} \times 2) - \text{measurement} (X1 + X2)$$

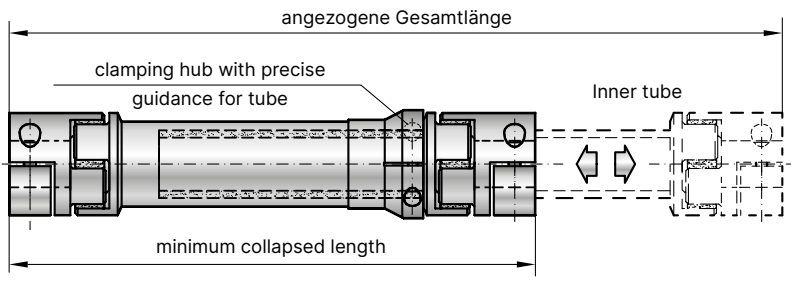

$$\text{Minimum collapsed length} = \frac{\text{maximum extended length} + \text{dimension} (X1 + X2)}{2}$$



Model EZV

Size		10		20		60		150		300		450		800	
Type (Elastomer insert)		A	B	A	B	A	B	A	B	A	B	A	B	A	B
Rated torque	(Nm) T_{KN}	12.5	16	17	21	60	75	160	200	325	405	530	660	950	1,100
Max. torque	(Nm) T_{Kmax}	25	32	34	42	120	150	320	400	650	810	1,060	1,200	1,900	2,150
Inserted min. length from - to	(mm) A_{min}	150 - 2,057.5		200 - 2,078		250 - 2,098.5		300 - 2,120		350 - 2,140		400 - 2,156		480 - 2,190	
Extended over all length from - to	(mm) A_{max}	185 - 4,000		244 - 4,000		303 - 4,000		360 - 4,000		420 - 4,000		488 - 4,000		580 - 4,000	
Measurement	(mm) X1+X2	115		156		197		240		280		312		380	
Outside diameter clamping hub	(mm) B_1	32		42		56		66.5		82		102		136.5	
Outside diameter tube section	(mm) B_2	28		35		50		60		80		90		120	
Outside diameter center hub	(mm) B_3	41.5		47		67		77		102		115		158	
Outside diameter with screwhead	(mm) B_s	32		44.5		57		68		85		105		158	
Fit length	(mm) C	20		25		40		47		55		65		79	
Inside diameter from \emptyset to \emptyset H7	(mm) $D_{1/2}$	5 - 16		8 - 25		14 - 32		19 - 36		19 - 45		24 - 60		35 - 80	
ISO 4762 clamping screw		M4		M5		M6		M8		M10		M12		M16	
Tightening torque	(Nm) E_1	4		8		15		35		70		120		290	
Screw ISO 4762		M4		M4		M5		M6		M8		M10		M12	
Tightening torque	(Nm) E_2	4		4.5		8		18		35		70		120	
Distance between centers	(mm) F_1	10.5		15.5		21		24		29		38		50.5	
Distance between centers	(mm) F_2	15		18		26		31		41		45		65	
Distance	(mm) G	7.5		8.5		15		17.5		20		25		30	
Coupling length	(mm) H	34		46		63		73		86		99		125	
Shaft average value	(mm) N	26		33		49		57		67		78		94	
Length	(mm) O	16.6		18.6		32		37		42		52		62	
Moment of inertia coupling half	(10^{-3} kgm ²) J_1/J_2	0.01		0.02		0.15		0.21		1.02		2.3		17	
Inertia of tube per meter	(10^{-3} kgm ²) J_3	0.075		0.183		0.66		1.18		2.48		10.6		38	
Combined dynamic torsional stiffness of the inserts	(Nm/rad) C_{Tdyn}^E	270	825	1,270	2,220	3,970	5,950	6,700	14,650	11,850	20,200	27,700	40,600	41,300	90,000
Torsional stiffness of tube per meter	(Nm/rad) C_T^{ZWR}	321		1,530		6,632		11,810		20,230		65,340		392,800	



For use in hazardous areas precision couplings

Based on the ATEX markings the product can be certified for suitability under certain conditions.

 	II	2G	Ex h	IIA T6	Gb	X
	II	2D	Ex h	IIIA T85°C	DB	X
	Equipment group	Category	Protection type	Explosion subgroup / Temperature class / max. surface temperature	Equipment protection level (EPL)	Additional features c

Equipment group	Approval type
I	Approved for underground operation
II	Approved for all other applications

Category	Approved for zone	Zone description
1G	0	Area in which an explosive atmosphere consisting of a mixture of air and flammable gases, vapors, or mists is present continuously, frequently or for long periods of time.
2G	1	Area in which the potential exists for an explosive mixture of air and flammable gases, vapors or mists to occur.
3G	2	Area in which the potential for an explosive mixture of air and flammable gases, vapors, or mists to occur is unlikely and only for a brief duration.
1D	20	Area with the same conditions as zone 0, with powder or dust.
2D	21	Area with the same conditions as zone 1, with powder or dust.
3D	22	Area with the same conditions as zone 2, with powder or dust.

Protection type	Definition
Ex h	Design safety level: ignition hazard is avoided by the product design.

Example classification by occurring gases, mists and vapors according to temperature class and explosion group

Temperature class / max. surface temperature	IIA	IIB (includes IIA)	IIC (includes IIA + IIB)
T1 / 450°C	Acetone, ammonia, methane, ...	City gas (gas lamp)	Hydrogen
T2 / 300°C	Ethyl alcohol, n-butane, cyclohexane, ...	Ethylene, ethylene oxide	Ethine (acetylene)
T3 / 200°C	Gasoline, diesel, heating oil, ...	Eethylene glycol, hydrogen sulfide	
T4 / 135°C	Acetaldehyde	Ethyl ether	
T5 / 100°C			
T6 / 85°C			Carbon disulphide

Equipment protection level according to IEC 60079	Importance
Ga	Very high protection level
Gb	High protection level
Gc	Extended protection level
Da	Very high protection level
Db	High protection level
Dc	Extended protection level

Additional mark	Importance
X	Special operating conditions (from description)
U	Part is a component. Conformity must be declared after installation in a device.

Socializing mit R+W

Would you like to learn more about R+W and our couplings?

We are pleased to take you into the world of R+W. On our YouTube channel, you can find several videos pertaining to our product line.

Are you more interested in application examples for our couplings?

If so, please take a look at our case studies that can be found on our homepage. Here you can also subscribe to the R+W newsletter.

And if you simply cannot get enough of us, you can find us on Facebook, Google+, and Twitter.



Perfect connections worldwide.



- | | | |
|--------------------|-------------|----------------------|
| Argentina | Indonesia | Russia |
| Australia | Israel | Saudi Arabia |
| Austria | Italy | Serbia |
| Belgium | Japan | Singapore |
| Bosnia-Herzegovina | Korea | Slovakia |
| Brazis | Lithuania | Slovenia |
| Chile | Macedonia | South Africa |
| China | Malaysia | Spain |
| Columbia | Mexico | Sweden |
| Croatia | Montenegro | Switzerland |
| Czech Republic | Netherlands | Taiwan |
| Denmark | New Zealand | Thailand |
| Estonia | Norway | Turkey |
| Finland | Peru | UK |
| France | Philippines | Ukraine |
| Greece | Poland | United Arab Emirates |
| Hungary | Portugal | USA |
| India | Romania | |

Qualität „Made in Germany“

Perfect connections worldwide.

R + W Antriebselemente GmbH

Hattsteinstraße 4
D - 63939 Wörth am Main
Phone +49 9372 986 40
Fax +49 9372 986 420
info@rw-kupplungen.de
www.rw-kupplungen.de

R+W Italia S.r.l.

Via De Amicis, 67
I - 20092 Cinisello Balsamo (MI)
Phone +39 02 262 641 63
Fax +39 02 243 085 64
info@rw-italia.it
www.rw-italia.it

R+W America

254 Tubeway Drive
USA 60188 Carol Stream, IL
Phone +1 630 521 9911
Fax +1 630 521 0366
info@rw-america.com
www.rw-america.com

R+W Büro asia pacific

No. 34, Jalan Permas 9/2
Bandar Baru Permas Jaya
Johor Bahru 81750
MALAYSIA
Phone +60 177 254177
jasontai@rwcouplings.com
www.rwcouplings.com

R+W Machinery (Shanghai) Co., LTD

Rm.606 Block B No.999 Zhou Hai Rd
Sunland International Building
Pudong 200131 Shanghai
China
Phone +86 21 586 829 86
Fax +86 21 586 829 95
info@rw-china.com
www.rw-china.com

R+W Büro france

600 Rue de Carlepont
F - 60400 Caisnes
Phone +33 972 179 660
Fax +33 972 631 749
info@rw-france.fr
www.rw-france.fr



The information included in this document is based on our present knowledge and experience and does not exclude the manufacturer's own substantial testing of the products. Drawings may differ from the original coupling. All data subject protection against third party claims. The sale of our product is in accordance with our general terms and conditions.

Version: 11/2024

THE COUPLING.



R+W Antriebselemente GmbH

Hattsteinstraße 4
63939 Wörth am Main
Germany

Phone: +49 9372-9864-0

info@rw-kupplungen.de

www.rw-couplings.com