

## S2 - 2-bolt pillow block bearing units with thread

Waterproof

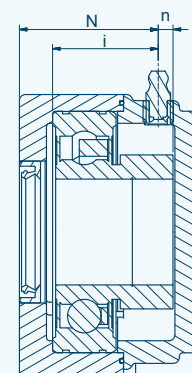

### Technical specifications & drawings

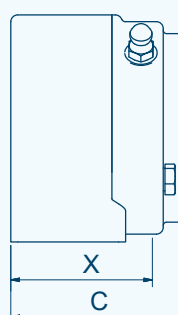
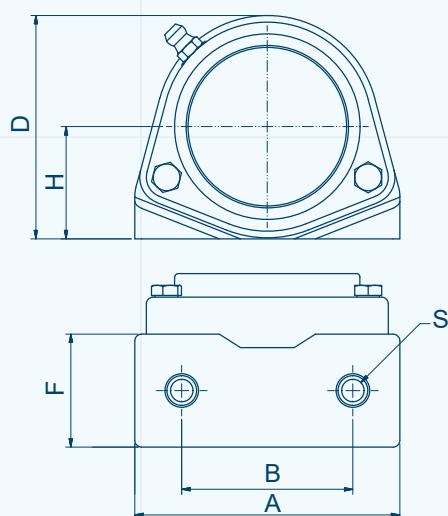

TYPE S2	Item no. closed cover	Item no. open cover	A	B	C	D	F	H	S	X	i	n	N	Weight [kg]
Ø20 mm	NG20S20	NG20S21	79	50,8	52	67	33,5	33,3	M8	38	27	4,5	31,0	0,40
Ø25 mm	NG25S20	NG25S21	87	50,8	53	73	34,5	36,5	M8	39	28	4,0	31,5	0,50
Ø30 mm	NG30S20	NG30S21	100	76,2	59	85	38,5	42,9	M10	45	34	3,2	36,7	0,80
Ø35 mm	NG35S20	NG35S21	110	82,6	60	93	38,5	47,6	M12	52	35	4,9	46,0	0,94
Ø40 mm	NG40S20	NG40S21	122	88,9	66	100	42,5	49,2	M12	58	40	5,2	51,0	1,30

All measurements are in millimeters. When ordering please use the catalogue numbers.

#### BJ-Gear A/S

Niels Bohrs Vej 47  
DK-8660 Skanderborg  
Denmark

Phone +45 87 40 80 80  
Email [bj@bj-gear.com](mailto:bj@bj-gear.com)  
Website [www.bj-gear.com](http://www.bj-gear.com)