

Input speed ( $n_1$ ) = 1400 min<sup>-1</sup>

Output speed $n_2$ [min <sup>-1</sup> ]	Ratio $i$	Motor power $P_{1M}$ [kW]	Output torque $M_{2M}$ [Nm]	Service factor $f.s$	Nominal power $P_{1R}$ [kW]	Nominal torque $M_{2R}$ [Nm]	Motor flanges			Dynamic efficiency RD	Tooth module [mm]	Ratios code		
							B5 motor flanges	B14 motor flanges						
							-	-	-Q 71	-R 80	-T 90			
200	7	1.8	71	1.8	3.2	125			B-C	B-C		83	3.1	01
140	10	1.8	99	1.4	2.4	134			B-C	B-C		81	3.1	02
93	15	1.5	121	1.1	1.7	138			B-C	B-C		79	3.1	03
74	19	1.1	111	1.2	1.4	138			B-C	B-C		78	2.6	04
58	24	1.1	135	1.0	1.2	142			B-C	B-C		75	2.0	05
47	30	1.1	167	0.9	0.96	146			B-C	B-C		74	3.2	06
39	36	0.75	125	1.2	0.88	147			B-C	B-C		68	2.7	07
35	40	0.75	135	1.0	0.78	140			B-C	B-C		66	2.5	13
31	45	0.55	111	1.2	0.67	135			B-C	C		66	2.1	08
23	60	0.55	140	0.9	0.51	130			B-C	C		62	1.6	12
21	67	0.55	151	0.8	0.45	124			B-C	C		60	1.5	09
17.5	80	0.37	115	1.0	0.38	119			B-C	C		57	1.3	10
14.9	94	0.37	123	1.0	0.36	119			B-C	C		52	1.1	11

**Motor flanges available**  
Flange motore disponibili



**B) Supplied with reduction bushing**  
Fornito con bussola di riduzione



**B) Available on request without reduction bushing**  
Disponibile a richiesta senza bussola di riduzione



**C) Motor flange holes position**  
Posizione fori flangia motore

## Lubrication

### Lubrificazione

Unit 163 is supplied with synthetic oil to assure long life lubrication. Food grade oil is available on request. See Table 1 for lubrication and recommended quantity. See Table 2 for possible radial and axial loads on the gearbox.

Il riduttore tipo 163 viene fornito con olio sintetico e lubrificazione tipo "long life". Disponibile a richiesta olio alimentare. Vedi Tabella 1 per oli e quantità consigliati. Vedi Tabella 2 per i carichi radiali e assiali applicabili al riduttore.

Shell Omala S4 WE 320

Eni Telium VSF 320

**B3**  
Standard  
0.60 L

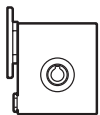

**B8**  
On request  
0.60 L

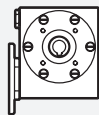

**B6**  
On request  
0.60 L

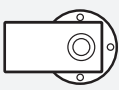

**V5**  
On request  
0.60 L

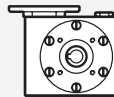

**B7**  
On request  
0.82 L

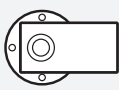

**V6**  
On request  
0.60 L

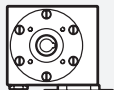

For more details on lubrication and plugs check our website.  
Per maggiori dettagli su lubrificazione e tappi olio vedi il nostro sito web.

Tab. 1

## Suggested

### Sugerito

Stainless steel protection cap (on request).  
Coperchio di protezione in acciaio inox a richiesta.

Kit cod. KI630211



## Radial and axial loads

### Carichi radiali e assiali

### Output shaft

#### Albero di uscita

$n_2$ [min <sup>-1</sup> ]	FA [N]	FR [N]
200	360	1800
150	400	2000
100	460	2300
75	500	2500
50	600	3000
25	700	3800
15	800	4000

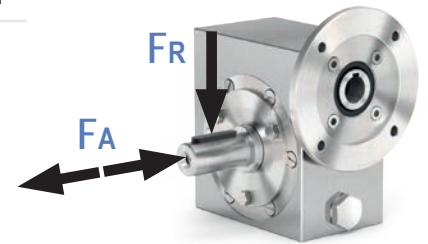

### Input shaft

#### Albero in entrata

$n_1$ [min <sup>-1</sup> ]	FA [N]	FR [N]
1400	90	450

\* Strong axial loads in the DX direction are not allowed.  
\* Non sono consentiti forti carichi assiali con direzione DX

Tab. 2

PI63UNI... **Basic gearbox**  
Riduttore base

Gearbox weight  
peso riduttore **14.6 kg**

M. flanges	Kit code	øF	A
71B14	KI634047	105	97
80B14	KI634046	120	99
90B14	KI634041	140	99

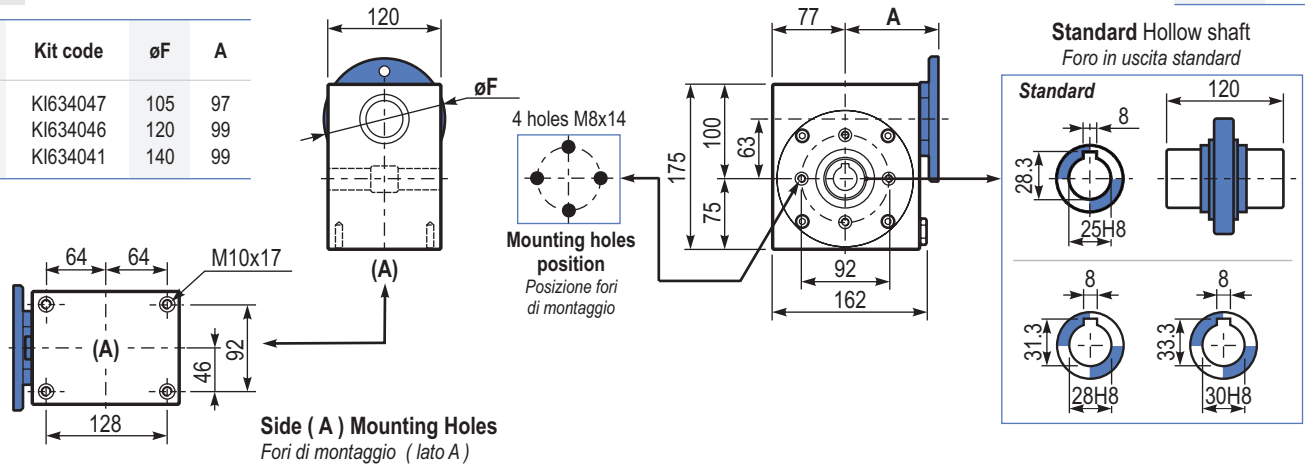

B I63UNI... **Modular base**  
Base modulare

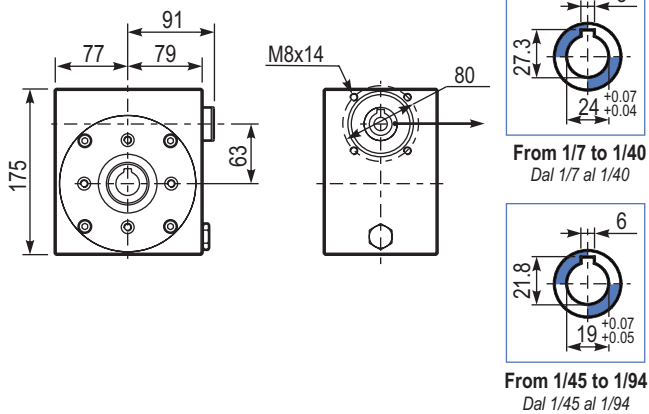

PI63FLL... **Output flange**  
Flangia uscita

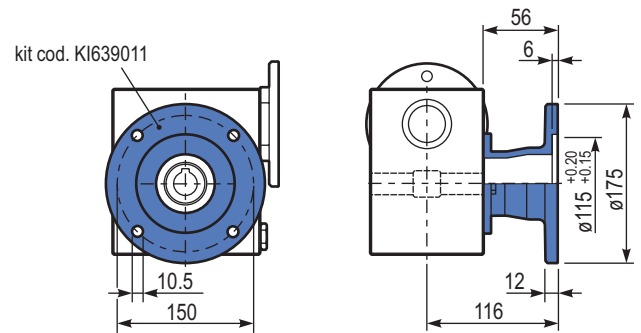

R I63UNI... **Input shaft**  
Albero in entrata

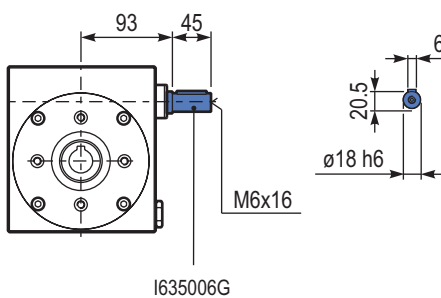

PI63BRI... **Reaction arm**  
Braccio di reazione

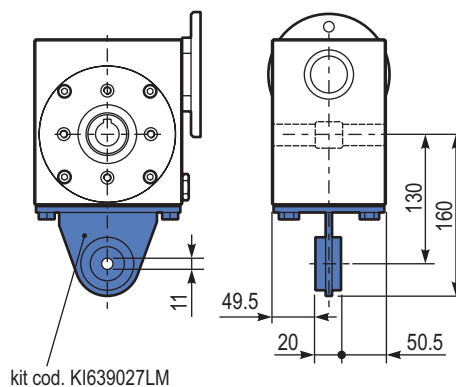

PI63...SMF... **Single Shaft**  
Albero lento semplice

